

THE AMERICAN MINERALOGIST

JOURNAL OF THE MINERALOGICAL SOCIETY OF AMERICA

Vol. 23

SEPTEMBER, 1938

No. 9

PREPARATION OF PETROFABRIC DIAGRAMS

JOHN C. HAFF, *Columbia University, New York City.*

INTRODUCTION

So far as known to the writer no paper presenting detailed procedures for preparing petrofabric diagrams has as yet appeared in English. The fundamental methods for the investigation of rock fabrics with the aid of the universal stage were created and developed abroad by Schmidt¹ and Sander.² Of late petrofabric studies in this country have increased in number and variety in a most encouraging manner. Several papers describing the results obtained by petrologists here have been published. The pioneering interpretative effort was made by Knopf in 1933.³ She presented a lucid discussion of the theories and objectives of petrofabric analysis as conceived by Professor Sander, and provided an excellent background concerning the concepts involved in such studies.

During the winter of 1936-37 the writer was privileged to study at the Mineralogic and Petrographic Institute of Leopold-Franzens University, in Innsbruck, Austria. He takes this occasion to thank Professor Sander for the hospitality, interest and assistance so graciously extended to him, and by his assistant Dr. Joseph Ladurner. It is the intention here to present a simplified, clear exposition of the general procedures currently used abroad in petrofabric studies. It is hoped that more petrologists will feel sufficiently encouraged to apply such methods to their particular problems. If even a modicum of interest in rock fabric investigations is aroused the writer will feel that some part of his obligation to the workers at Innsbruck will have been repaid.

A somewhat more detailed description of the general procedure than heretofore available in English will be given. Such workers as Gilluly,⁴

¹ Schmidt, Walter, Gefügestatistik: *Tschermaks Min. u. Petr. Mitt.*, vol. 38, pp. 392-423, 1925 (Festband Friedrich Becke). Also *Tektonik und Verformungslehre*, Gebrüder Borntraeger, Berlin, 1932, pp. 208.

² Sander, Bruno, *Gefügekunde der Gesteine*. Julius Springer, Vienna, 1930, pp. 352.

³ Knopf, Eleanor Bliss, *Petrotectonics: Am. Jour. Sci.* (5), vol. 25, pp. 433-70, 1933.

⁴ Gilluly, James, Mineral orientation in some rocks of the Shuswap terrane as a clue to their metamorphism: *Am. Jour. Sci.* (5), vol. 28, pp. 182-201, 1934.

Ingerson,⁵ Bell,⁶ Fairbairn⁷ and others have published articles amply demonstrating the value of the statistical approach. In parts of their papers are comments and instructions on various phases of the procedure. To avoid repetition, where one of these students has amplified some particular phase of the subject here dealt with, specific references will be given. To reach as large an audience as possible, step-by-step procedures are presented, and to aid in visualization considerable illustrative material is included. Those with a foreknowledge of universal-stage technique, may, perhaps, find some of this detail of no particular interest. In such a case, the scope of the subject matter treated will, it is hoped, furnish a satisfactory guide to the preparation of petrofabric diagrams in the conventional manner.

PREPARATION FOR MEASUREMENT

Collecting the specimen

When collecting the specimen it is necessary to note carefully the strike and dip of conspicuous structures. The specimen is first knocked off the outcrop, replaced in its original position, and the geographical coordinates of the structures determined. The strike and dip should be placed directly on the specimen whenever feasible. If the rock is not sufficiently smooth, adhesive tape can be applied and strike and dip written on in indelible pencil. Or the direction of strike and dip can be scratched on with a dental pick; the specimen number applied; and the coordinates placed in the notebook. Comments and sketches should be set down while at the outcrop so that the structural association and the particular problem involved are clearly stated.

Assignment of reference axes

According to Sander an *s*-surface may be defined as any conspicuous surface of parting such as a plane of schistosity, foliation, shear, or bedding. For convenience in reference a triaxial coordinate system is used to designate the relationships of the linear and planar structural features in a rock specimen. Axes, known respectively as "*a*," "*b*," and "*c*," are assigned with definite regard to visible rock structures wherever such are present. Thin sections are usually cut perpendicular to these axes of reference. The above mentioned axes need have no necessary relation to

⁵ Ingerson, E., Fabric analysis of a coarsely crystalline polymetamorphic tectonite: *Am. Jour. Sci.* (5), vol. 31, pp. 161-87, 1936.

⁶ Bell, James F., Festigkeit und Gefügeregel am Beispiel eines Granits: *Neues Jahrb. Min., Geol.*, vol. 71, BB. Abt. A., pp. 193-213, 1936.

⁷ Fairbairn, H. W., Introduction to petrofabric analysis, 1935, pp. 142. (Issued by the Dept. of Geology, Queens University, Kingston, Canada.)

the geographical coordinates of the specimen such as strike and dip. In large part the function of the axial nomenclature is to provide a set of coordinates for correlating the fabric elements in the rock with a reference sphere used as a basis for plotting statistical results. These axes are closely analogous in function to those employed in crystallography as a basis for morphological descriptions. The attitude and disposition of such rock structures as foliation planes, joints, bedding planes, folds, faults, fractures, and directions of mineral parallelism can be readily described with the use of such axes.

The "a" axis indicates the assumed direction of relative movement or transport of material. The "a" axis lies in the *s*-surface and, together with "b," defines the plane parallel to which relative shearing movements have taken place. When there has been bodily movement of grains, or parts of individual grains, past one another, the plane of slip, or the *s*-plane, corresponds to the plane "ab." In the case of folded rocks transport and slip take place in the direction of dip of the fold.

The "b" axis is the axis of slip normal to the direction of slip "a," and perpendicular to the plane "ac." In movements which produce external rolling of one set of mineral particles with respect to another set, "b" is the axis of internal rotation. The "b" axis is the axis of folding and its direction is said to be the "tectonic strike" of the fold.

In a hand specimen the "b" axis may frequently be detected by the alignment of mineral grains visible on the *s*-surface. It may manifest itself as the axis of a fold.⁸ Or its location may be suggested by the line of intersection of two or more shear surfaces. In selecting surfaces for thin sections the "b" axis is assumed to be the direction of conspicuous structure which is visible on the *s*-surface, i.e., in the plane "ab." Thus the "b" axis might be the direction of minute crumplings in the foliation plane of a pencil slate; the direction of parallelism of hornblende needles in the foliation plane of a gneiss; or, in a ripple-marked sandstone, the direction of the wave crests. Experience indicates⁹ that rotation about "b" is a very frequently recurring phenomenon, and also that the "b" axis is often horizontal. Hence, as it may well be the most informative means of attack on the major fabric elements of a rock, the thin section normal to "b" is usually the first to be studied in detail.

The "c" axis is normal to the plane "ab," and, therefore, perpendicular to the *s*-surface. Axes "a" and "c" define the plane standing normal to the *s*-surface.

Preparation of thin sections

When the structures on the hand specimen have been identified and

⁸ Knopf, E. B., *opus cit.*, p. 452.

⁹ Sander, B., *opus cit.*, p. 59.

the axes of reference located, thin sections normal to these axes are cut as a first step toward microscopic investigation. Usually the thin section maker is not cognizant of the procedures by which the axes are selected. To obviate this difficulty surfaces to be measured are ground plane before the specimen is submitted to him. Three faces respectively perpendicular to the axes of reference are usually ground on the specimen. Arrows, and other distinguishing marks, in India ink, are placed on these surfaces, parallel, or sometimes perpendicular, to the direction of the structures visible on the surface. Before the section is cut it is well to make a simple sketch of the hand specimen showing the general outlines, the trace of the structures, the location of the ground surfaces, arrows and other symbols. The thin section preparator should be instructed that the

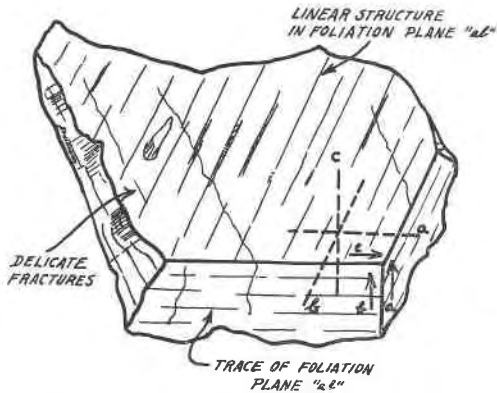

FIG. 1. Sketch of a specimen of gneiss with three perpendicular faces ground ready for sectioning.

section is to be made directly from the marked, ground surface by cementing the object glass to that surface. The ground surface should be marked in such a manner as to indicate the approximate dimensions and outlines of the completed section. If the ground surface has a straight edge, or if a definite line of direction is visible on the surface, the straight edge must be preserved if possible, and the direction line set parallel to the edge of the object glass. All direction marks and symbols on the ground surface must be transferred to the object glass with a diamond point in exact correspondence with those on the specimen. The number of the specimen and the orientation of the section must also be permanently and clearly marked on the object glass.

The place on the specimen from which the section was cut should be marked by the section maker so that the specimen and the rock slice can be correlated. For most purposes sections should be ground as thin as possible. The rock slice should be embedded in well-cooked balsam

because of the danger of mashing or twisting the slice if the segment mount is accidentally screwed down too far. All remaining pieces of the hand specimen should be returned. If any of these precautions are neglected considerable trouble in orientation may ensue and erroneous results be obtained. Ingerson¹⁰ has recently designed a helpful apparatus for setting up the specimen according to its geographical coordinates; obtaining the coordinates of structure planes; and accurately orienting the thin section.

SUPPLEMENTARY OBSERVATIONS TO BE MADE DURING MEASUREMENTS

As designated by Ingerson there are, in general, two major types of diagrams, *elemental* and *collective*. He states: "*Elemental* diagrams are units that are combined to form other diagrams known as *collective* diagrams." And: "A *collective* diagram is prepared by collecting the points from a number of similar elemental diagrams, commonly from the same thin section, into a single diagram." He also establishes a class of diagrams called *partial* diagrams "which are elemental diagrams that have been prepared by a definite selection of grains."¹¹

In the very beginning a large scale drawing of the thin section is made so that the areas covered in each traverse can be re-located at will. In examining the thin section, both before and during measurement, care should be taken to note any other visible evidences of orientation present in addition to the well defined structural features selected as the basis for locating the axes of reference. Whenever such structures are found, separate detailed measurements of them should be made. In this way structures which at first appear subordinate may eventually be found to be of basic importance. The need for additional partial diagrams of subdued features very frequently becomes evident only after many grains have been measured. Sometimes only the finished diagram will indicate emphatically the presence of structures which have otherwise eluded search. When fabric elements are thus revealed, new thin sections may have to be cut and additional measurements made.

If any concentration of poles becomes evident on the elemental diagrams, the thin section and the hand specimen should be studied and compared to detect such superficial manifestations as may be present. The fundamental purpose in making a diagram is not solely the production of the contoured diagram itself, although the latter is of unquestionable value for comparison and depiction of the internal grain

¹⁰ Ingerson, E., Accurate orientation of thin sections: *Am. Mineral.*, vol. 22, pp. 760-72, 1937.

¹¹ Ingerson, E., Fabric analysis of a coarsely crystalline polymetamorphic tectonite. *Am. Jour. Sci.* (5), vol. 31, pp. 171-72, 1936.

relationships. During plotting, elusive fabric elements may become manifest through the grouping or localized concentration of poles. Such indications suggest the presence of hidden features which should be thoroughly investigated. Only in this way can the sequence of movements and the developmental history of the rock be determined.

During measurement, as elemental diagrams are made, grains with notable features as, for example, textural variation or alternation; unusual internal structures; suggestive distribution with respect to particular minerals; or distinctive boundary relations, should be indicated by the use of different pole symbols. Possibly quartz grains in contact with tourmaline, or those poeciloblastic with respect to garnet might be singled out by using special symbols for the poles of grains with such distribution. Quartz grains in contact with muscovite, as compared with those in contact with grains of calcite, might be tentatively distinguished by separate pole symbols. In a mylonitized rock, grains of quartz in contact with the original feldspars could be designated in a different manner from quartz grains in the surrounding mesostasis of the rock. By such selective plotting significant organization of the grains can be detected *as measurement proceeds*.

Axes of the universal stage

To ascertain the nature of a rock fabric, according to the fundamental methods developed by Sander and Schmidt, the position in space of the optic axis of each measured grain of the selected mineral must usually be determined. Methods for the identification of uniaxial minerals with the universal stage have been given by Berek¹² and Reinhard¹³ and others. But their instructions are primarily for determining the form of the indicatrix as a basis for distinguishing uniaxial from biaxial minerals. The procedure for measuring the optical orientation of uniaxial minerals of known identity can be reduced to a definite routine. Fairbairn¹⁴ has given a procedure for measuring the optical orientation of uniaxial minerals. His treatment of this subject seems to presuppose a rather broad familiarity with universal-stage methods in general. Unfortunately instruction in the use of this instrument is, at present, not nearly so widespread as might be desired.

The procedures here given, though simplified, are believed to be suitable as an outline of the essential technique. Certain minor steps in manipulation, which may be dispensed with when the general orientation

¹² Berek, Max, *Universaldrehtischmethoden*, Gebrüder Borntraeger, *Berlin*, 1924, pp. 64-65.

¹³ Reinhard, Max, *Universaldrehtischmethoden*, B. Wepf e Cie, *Basel*, 1931, pp. 18-21, 23-24.

¹⁴ Fairbairn, H. W., *opus cit.*, pp. 17-18.

of the crystal is firmly in mind, have been included. It is believed that a general knowledge of the optics of uniaxial crystals will be found a sufficient basis for understanding the various steps.

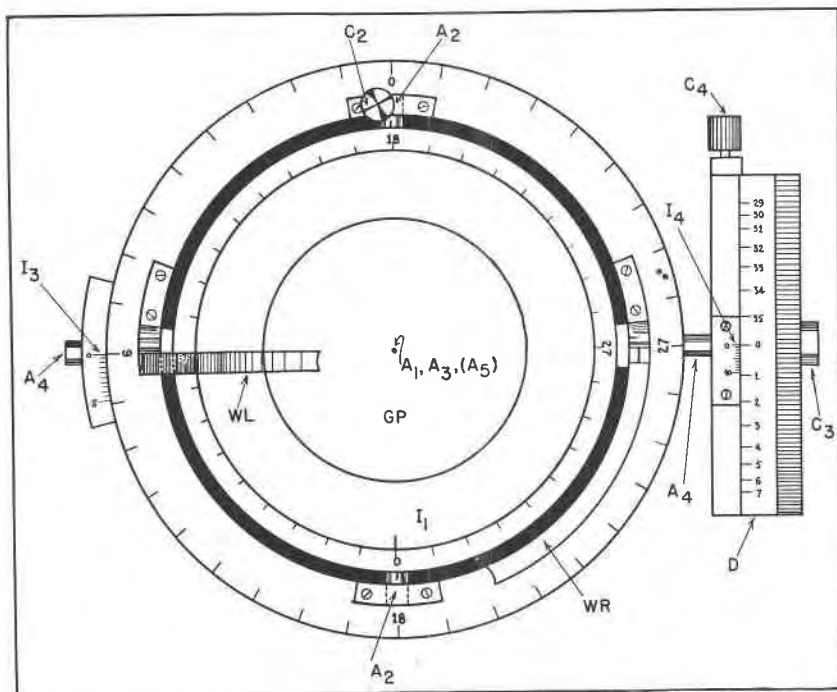

FIG. 2. Diagram of a standard 4-circle universal stage. A₁, A₂, A₃, A₄, and A₅ (microscope axis) = the several axes; C₂, C₃, C₄ = the arresting screws of axes A₂, A₃, A₄ respectively; I₁, I₃, I₄ = the indices of axes A₁, A₃, A₄; D = calibrated drum of A₄; GP = the glass plate; WL and WR = calibrated arcs of A₂, left (erect) and right (reclining).

The various axes of the 4-circle universal stage are here designated according to the system of Berek.¹⁵

Axis A₁: The axis of rotation of the innermost ring which supports the glass plate, thin section, and segments. This axis is at all times the direction of the normal to the thin section. Axes A₁ and A₂ form the first pair of mutually perpendicular axes. (See Fig. 2.)

Axis A₂: The north-south horizontal axis.

Axis A₃: The vertical axis of the outer circle of the universal stage. The A₃ axis coincides with the microscope axis when the stage is in proper adjustment. Axes A₃ and A₄ form the second pair of mutually perpendicular axes.

Axis A₄: The east-west horizontal axis. This axis is controlled by the large graduated drum.

Axis A₅: The axis of the object stage of the microscope, and, therefore, coincident with the microscope axis.

¹⁵ Berek, Max, *opus cit.*, pp. 9-11.

Detailed instructions for mounting and adjusting the universal stage cannot be given here. The reader is referred to the standard texts of Berek,¹⁶ Reinhard,¹⁷ and Nikitin,¹⁸ and to the works of Emmons,¹⁹ Winchell,²⁰ and Fairbairn.²¹

ACCESSORIES

Description of Schmidt net

In constructing petrofabric diagrams the poles of optic axes, and of the normals to cleavage and twinning planes, are plotted on an equal-area projection devised by Schmidt.²² This net is a projection of the surface of the southern hemisphere of a hollow reference sphere. With the more common angle-true stereographic projection poles on the upper hemisphere of the reference sphere are plotted. In contrast to this, in rock fabric analysis the data are plotted on a surface-true projection of the lower hemisphere of the reference sphere.

The measured crystal is imagined to be lying at the center of a sphere of reference. The points of intersection of the normals to crystal planes with the surface of the sphere are called poles. Any axis, or any normal to a reference plane in the crystal, if prolonged to the surface of the sphere, has two antipodal poles. In measuring the optical orientation of a mineral grain the azimuth and altitude of the pole in question is determined with the universal stage.

The fundamental circle of the Schmidt projection is 20 cm. in diameter. Degrees of azimuth are marked on the circumference of the net at ten-degree intervals. When the customary four-circle universal stage is used, degrees of azimuth are laid off counterclockwise from the 0-degree mark (south point) on the net circumference. The figures then run in the same order as the calibrations on the graduated circle of A_1 . Arcs of inclined great circles at 2-degree intervals are projected on the net. All these great circles pass through the equatorial plane of the reference sphere along a diameter whose trace on the net is the 0–180° meridian. The arcs of vertical small circles are also projected at 2-degree intervals. In this way interpolation during construction and rotation is made practicable. The fundamental circle of the net is itself the projection of the circumference of the equatorial plane of the reference sphere, i.e., the only possible horizontal great circle. The north-south diameter (0–180°

¹⁶ Berek, Max, *opus cit.*, pp. 31–39.

¹⁷ Reinhard, Max, *opus cit.*, pp. 37–45.

¹⁸ Nikitin, W., *Die Fedorow-Methode*, Gebrüder Borntraeger, Berlin, pp. 15–27, 1936.

¹⁹ Emmons, R. C., In "Microscopic Characters of Artificial Minerals" by A. N. Winchell, p. 144, 1931.

²⁰ Winchell, A. N., *Elements of Optical Mineralogy*, pp. 225–27, 1931.

²¹ Fairbairn, H. W., *opus cit.*, pp. 14–15.

²² Schmidt, Walter, *opus cit.*, pp. 395–96.

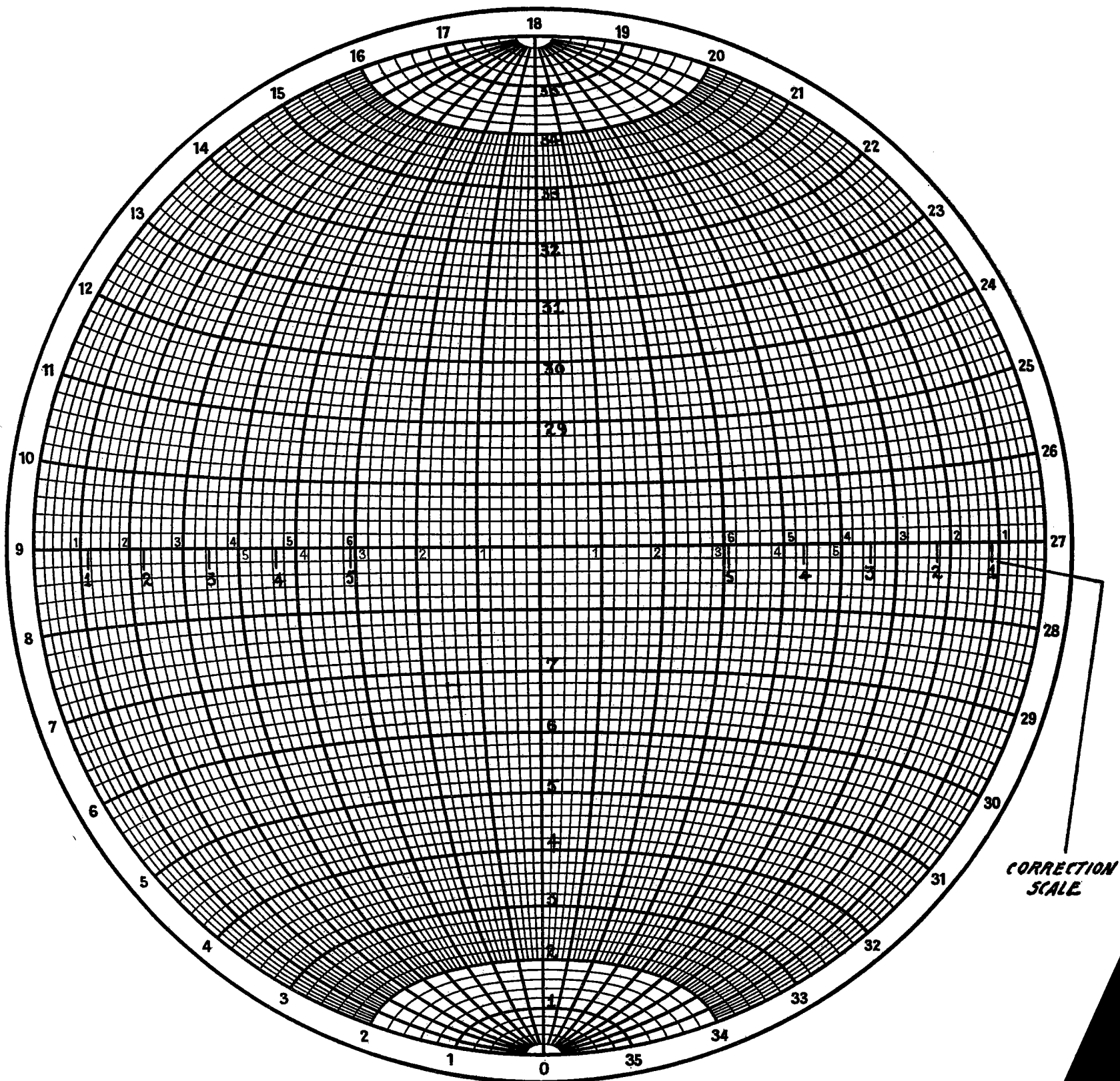

FIG. 3. Schmidt net showing the various scales used in plotting.

meridian) of the projection is the trace of the vertical great circle which passes through the north and south poles of the reference sphere. The east-west diameter (90–270° meridian) is the trace of the largest possible vertical small circle, which is a limiting case and at the same time a great circle.

On the prepared Schmidt nets there are two sets of figures lying along the east-west diameter. The dotted figures below the east-west diameter begin at the center and increase to right and left. When quartz or calcite are measured this set of figures is used to plot the poles of optic axes when the latter are brought into coincidence with the microscope axis. Two other groups of figures begin at the east and west points on the circumference and increase toward the center. These are used, when quartz is measured, for plotting the pole after the optical equator is brought parallel to the microscope axis. Two other groups of figures, beginning at the east and west points should be placed along this diameter. They are used when plotting the optic axes of calcite crystals after the optical equator has been brought parallel to the microscope axis. They furnish the necessary angular corrections due to the difference in refractive index between the "e" rays of calcite (1.486) and that of the segments (1.64 approx.). These corrections can be obtained from the nomogram of Berek,²³ or from the diagram of Emmons.²⁴ The net here reproduced shows the positions of the correction figures accurately enough so that they may be transferred from the illustration if desired (Fig. 3).

Two sets of figures should be placed beside the north-south meridian. Beginning from the 180° point on the circumference the figures 36 (usually omitted), 35, 34, 33, etc., in descending order toward the center are plotted. From the 0° figures 0 (usually omitted), 1, 2, 3, etc., in ascending order toward the center are set down. These figures correspond to the calibrations on the drum of A₄. They are used when plotting the poles of the normals to twinning and translation planes in calcite after the trace has been brought into the east-west position. They are also used for plotting the pole when the cleavage trace of a mica crystal is brought parallel to the east-west crosshair.

Schmidt sledge and its use

Usually, for statistical purposes, an insufficient number of grains are encountered in a single traverse, even in a rock of relatively fine grain. A number of successive traverses must then be made across the section. For valid results, in any given set of measurements, all traverses should be parallel to the selected structural line of reference. It is hardly possible

²³ Berek, Max, *opus cit.*, p. 57 and Table I.

²⁴ Emmons, R. C., A modified universal stage: *Am. Mineral.*, vol. 14, p. 450, 1929.

to move the section straight across the universal-stage platform and preserve identical orientation without mechanical aid. To assist in keeping the section properly oriented, Schmidt designed a "*Parallelführer*" or guide, sometimes called a "sledge." This is a right-angled metal bracket which is attached to the upper segment mount. One arm of the sledge fits into a north-south channelway on the upper surface of the

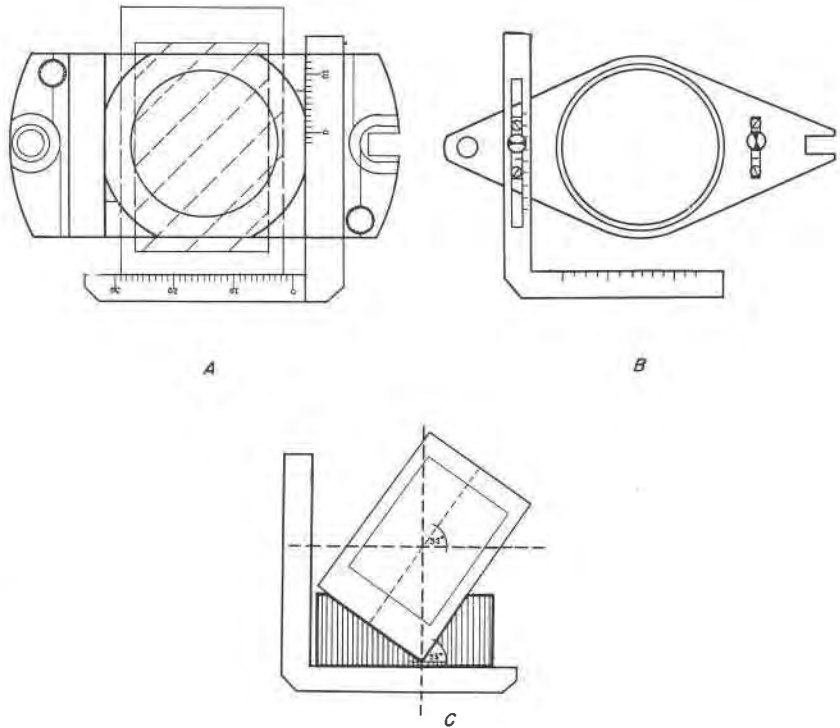

FIG. 4. A. Type of segment mount which can be purchased already slotted for use with the Schmidt sledge.

B. Ordinary segment mount adapted for use with the sledge.

C. Sketch illustrating use of cellulosid angle plates employed in making an oblique traverse.

mount. The other arm, against which the section rests and by means of which it is guided, projects beyond the mount and extends east-west. There are several types of segment-mounts in use at present. Two of these are illustrated. If the segments at hand are not fitted for using the guide, they can be readily adapted (Fig. 4A and B).

The section is moved along the guiding edge with the fingers, each grain measured being centered as well as possible. The arm by which the

sledge is attached to the segment mount can be moved up or down and firmly fixed in position. By adjustment of this arm a different line of section can be examined each time. So long as the lower edge of the thin section is held firmly against the east-west arm of the sledge, successive parallel traverses are obtained.

To examine a sufficiently large area of the thin section, it may be necessary to cut off part of the object glass. If this is done care must be taken to cut squarely across the preparation exactly at right angles to the long direction of the object glass. Otherwise, when mounted, the section will lie askew and subsequent traverses will not be parallel to the earlier ones.

Structures of the rock fabric which make an angle with the edge of the thin section must often be traversed. To investigate them the section must be crossed obliquely. This is often very difficult because of the small range through which the section may be tipped, and because appreciable lateral displacement is prohibited due to interference with the studs holding the segment mount. If, when the section is tipped, even a small part of the object glass projects beyond the inner circle of the stage, measurement is greatly restricted. It is often impossible to proceed without beveling the object glass. In such cases a corner is cut off so as to make a sufficiently long bevel to prevent the section from rocking when laid against the sledge. Using celluloid or thin metal guides, into which notches have been cut, it is sometimes feasible to measure without trimming the section (Fig. 4C). Whether the object glass is beveled, or accessory guides employed, care must be taken to check the orientation of the section frequently during measurement.

MEASUREMENT OF UNIAXIAL MINERALS WITH THE UNIVERSAL STAGE

After the thin section has been properly mounted every grain of the selected mineral encountered in the traverses should be measured if feasible to do so. It may happen that the observed crystal is at extinction after centering. It is then necessary to determine whether the optic axis coincides with the microscope axis, or whether it lies, fortuitously, parallel to one of the vibration directions of the microscope. If, now, the section is rotated by turning about A_5 and the crystal becomes illuminated, then the optic axis does not coincide with the microscope axis. It is, therefore, either inclined to, or lies in, the plane of the section. In the following discussion, after the crystal has been adjusted so that the optic axis coincides with the microscope axis, the grain is said to be in the *polar position*. If some diameter in the equatorial plane of the indicatrix is brought into coincidence with the microscope axis, the crystal is said to be in the *equatorial position*.

Measurement when optic axis is inclined to the plane of the section

We will assume that the crystal is illuminated after centering. The measured grain is known to be uniaxial, and is, let us say, quartz. Starting from the rest position:

E 1a. Rotate about A_1 and bring the grain to a position of extinction. (In the following, essential steps are designated "E.")

Since the crystal is at extinction the optic axis lies parallel to the plane of vibration of either the polarizer or analyzer. But it is not known whether the optic axis is parallel to the north-south or to the east-west vibration plane. Nor is it known whether the optic axis is parallel, or inclined, to the plane of the section. To distinguish these two cases:

E 2a. Rotate a few degrees about A_2 .

If the crystal becomes illuminated the optic axis is inclined to the plane of the section and parallel to the north-south crosshair. If the crystal remains at extinction, refer to step "1b" in the following section on measurement when the optic axis lies in the plane of the section.

E 3a. Return to the 0-degree position on A_2 .

To verify the north-south position of the optic axis:

4a. Rotate a few degrees on A_4 .

The grain should now remain at extinction, if the optic axis extends north-south. If the crystal is in this position its orientation cannot be measured. For when the section is rotated about A_2 it becomes illuminated, and if then rotated about A_4 it remains illuminated. Hence it is impossible to bring the crystal from a position of illumination to one of extinction. Therefore:

E 5a. Rotate the section 90 degrees on A_1 to the next position of extinction.

The optic axis should now lie east-west parallel to the A_4 axis. To verify this:

6a. Rotate a few degrees on A_2 , ascertain that the crystal remains dark, and return to the 0-degree position on this axis. As an additional check one may:

7a. Rotate a few degrees on A_4 .

Since the optic axis is inclined to the plane of the section (as determined in 2a), the grain will become illuminated. To determine the coordinates of the optic axis:

E 8a. Rotate, forward or backward, about 30–35 degrees on A_4 , leaving the stage in this position.

E 9a. Rotate, right or left, on A_2 and bring the crystal to extinction.

E 10a. Rotate back to the 0-degree position on A_4 .

The crystal will now be in either one of two positions depending on

the original inclination of the optic axis with respect to the plane of the section. Either the optic axis coincides with the microscope axis, or some diameter in the plane defined by the horizontal crystallographic axes (the "equatorial plane" of the indicatrix) coincides with the microscope axis. In this latter case the optic axis coincides with axis A_4 . Before the pole can be plotted, it is necessary to distinguish between these two positions. This is done by:

E 11a. Rotating about A_5 .

If the optic axis coincides with the microscope axis, the crystal will remain at extinction. If some diameter in the equatorial plane of the indicatrix lies in the observation direction, the crystal becomes illuminated. The procedures for plotting the pole of the optic axis is different in each case and separate directions are given later.

Measurement when the optic axis lies in the plane of the section or nearly so

If in step 2a the crystal remains at extinction, the optic axis is either inclined to the plane of the section and lies parallel to the east-west vibration plane, or it lies in the plane of the section, or nearly so. To distinguish these two positions and to determine any slight deviation of the optic axis from the horizontal:

E 1b. After returning to the 0-degree position of the A_2 axis (step 3a), rotate about A_4 .

If the grain remains at extinction after rotation about both A_2 (step 2a) and A_4 (step 1b), the optic axis lies in the plane of the section or very nearly so. Then:

E 2b. Return to the 0-degree position on A_4 and proceed with step 3b.

(Note: If the optic axis is inclined to the plane of the section and lies east-west, the crystal will become illuminated when rotated about A_4 in step 1b. In this case return to the 0-degree position on A_4 and proceed with step 8a above.)

The equatorial plane of the indicatrix is perpendicular to the optic axis. When the optic axis lies in the plane of the section the equatorial plane is vertical and some diameter in this plane coincides with the microscope axis. If, then, the optic axis is brought parallel to one cross-hair, the trace of the equatorial plane coincides with the other. Then, upon rotation about both A_2 and A_4 from the rest position the crystal will remain at extinction. Having determined in 1b that the optic axis lies in the plane of the section, or nearly so, the next step is to ascertain whether the axis is parallel to the east-west or north-south crosshair. Verify that axes A_2 and A_4 are at their 0-degree position; then:

E 3b. Rotate a few degrees about A_2 . Leaving the inner stage in this position

E 4b. Rotate about A_4 and return to the 0-degree position of this axis. If the grain remains dark the optic axis lies north-south and the crystal is in the wrong position for measurement. If the axis lies north-south, proceed with step 6b. If the crystal becomes illuminated, proceed with step 7b. In either case to avoid confusion first:

E 5b. Rotate back to the 0-degree position of A_2 .

E 6b. Rotate 90 degrees on A_1 to the next position of extinction and bring the optic axis east-west.

E 7b. Rotate approximately 15–20 degrees on A_2 .

E 8b. Rotate on A_4 , forward or backward, far enough to bring the crystal to the position of maximum illumination.

E 9b. Rotate back on the A_2 axis and bring the grain to extinction.

In so doing some diameter in the equatorial plane of the indicatrix is brought into coincidence with the microscope axis. The optic axis should now coincide with A_4 .

E 10b. Rotate back to the 0-degree position on the drum of A_4 and take the readings.

To verify that the optical equator stands vertical:

E 11b. Rotate about A_5 .

If the grain becomes illuminated, an equatorial position was secured, as should be the case. Since the "optical equator," defined by the horizontal crystallographic axes, is normal to the optic axis, when the orientation of this plane is known the pole of the optic axis can be plotted.

Measurement when the optic axis is coincident, or nearly so, with the microscope axis

If the grain was dark when first centered and remained at extinction upon rotation about A_5 , the optic axis coincides in direction, or nearly so, with the microscope axis. When the crystal is thus oriented, it is difficult to decide whether the observed extinction is complete or partial. It is often helpful to move the optic axis a few degrees off the vertical, bring it back, and to note as carefully as possible the moment of extinction as the crystal is brought from a position of illumination. To do this:

E 1c. Rotate approximately 15–20 degrees about A_2 .

E 2c. On A_4 rotate a few degrees forward or backward. The grain becomes illuminated.

E 3c. Rotate back on A_2 searching as carefully as possible for the actual position of complete extinction.

E 4c. Return to the 0-degree position on the drum of A_4 . If it is desired to verify the orientation:

5c. Rotate about A_5 .

If the optic axis has been properly adjusted into coincidence with the

microscope axis, the grain will now remain at complete extinction through a rotation of 360 degrees.

PLOTTING

Assembly: A circle 20 cm. in diameter is inscribed on a sheet of thin transparent paper. The tracing paper is superposed on the Schmidt net so that the center of the circle coincides with the center of the projection. The tracing paper is then fastened to the center of the net with a pin so that the sheet can rotate freely. An arrow is placed on the circle drawn on the tracing paper exactly over the 0-degree point on the net circumference.

Plotting when a polar position is obtained:

1. Rotate the tracing paper until the arrow lies at the point on the circumference of the net corresponding to the reading of A_1 (Fig. 5B).
2. Along the east-west diameter of the net *count out from the center* the number of degrees of rotation about A_2 and plot the pole.

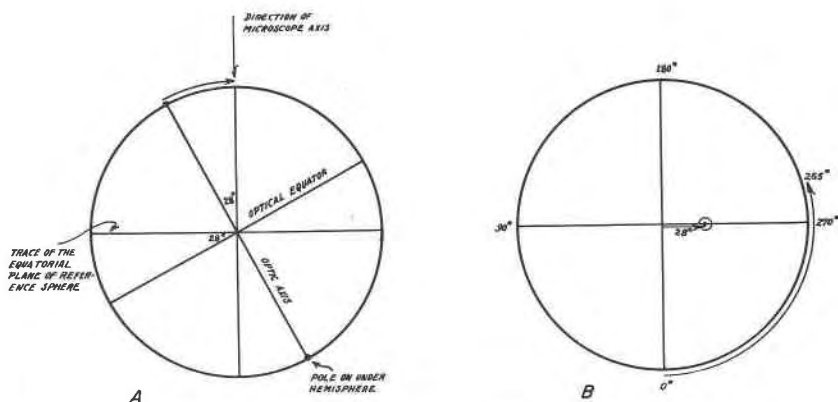

FIG. 5. Polar Position. Coordinates A_1 : 265° , A_2 : $28^\circ L$.

A. Relationship of indicatrix and reference sphere.

B. Diagram illustrating method of plotting pole of optic axis.

If for example, the A_2 reading is taken from the left arc of A_2 , the optic axis is inclined from left to right (Fig. 5A). Only poles on the lower hemisphere of the reference sphere are plotted. Hence when the optic axis is so inclined, the pole of the lower extremity is plotted on the right side of the net. Conversely, if the optic axis is inclined from right to left, i.e., its inclination is read off the right arc, the pole is plotted on the left side of the net.

Plotting when an equatorial position is obtained:

1. Rotate the tracing paper until the arrow lies at the point on the net circumference corresponding to the reading of A_1 .

2. Along the east-west diameter *count in from the circumference* of the net the number of degrees of rotation upon A_2 and plot the pole (Fig. 6B).

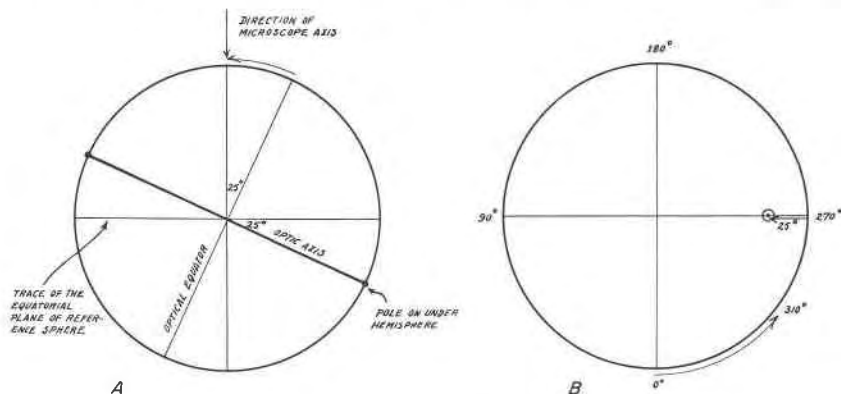

FIG. 6. Equatorial Position. Coordinates A_1 : 310° , A_2 : $25^\circ R$.

A. Relationship of indicatrix and reference sphere.

B. Diagram illustrating method of plotting pole of optic axes.

If, for example, the A_2 coordinate is read off the right arc, the optical equator is inclined from right to left. The optic axis, being normal to the optical equator, is therefore inclined from left to right (Fig. 6A). Its pole on the under hemisphere is plotted on the right side of the net. If, having secured an equatorial position, the degrees of rotation are read from the left arc, the pole of the optic axis is plotted on the left side of the net.

CONSTRUCTING THE PETROFABRIC DIAGRAM

Making the collective diagram from elemental diagrams

To derive the contoured diagram, poles plotted on the individual elemental diagrams are transferred to one sheet of tracing paper.

Assembly: Prepare a sheet of tracing paper with a circle 20 cm. in diameter and place an index mark (an arrow perhaps) on the circumference. One of the elemental diagrams is fastened to the drawing board. The prepared sheet of tracing paper, which later becomes the collective diagram, is superposed so that its center coincides with that of the elemental diagram. The index mark on the superposed sheet is brought into coincidence with the index mark of the underlying diagram. The two sheets are firmly fastened down together so that they cannot shift relative to one another.

Procedure: On the upper sheet a dot is placed over each pole on the diagram beneath. When all points are transferred, this elemental diagram

is removed and another substituted. The same upper sheet is again centered and its index mark brought into coincidence with that of the diagram now underneath. All poles on the second diagram are transferred as before. When all poles on each elemental diagram are transferred to this one piece of tracing paper the collective diagram is complete.

Determining the percentage distribution of poles on the collective diagram

A piece of millimeter cross-section paper about 40×40 cm. square; another sheet of tracing paper; and two celluloid counting templates are now required. The coordinate paper should have heavy centimeter lines so that the counting devices can be easily centered. The dimensions of the counting device are dictated by the following considerations. To make a finished diagram, contours are drawn through points about which are distributed a certain number of poles. The number of poles assigned to each point of reference on the coordinate paper represents a definite percentage of the total number of grains measured. The diameter of the projection upon which poles are plotted is 20 cm. A circle 2 cm. in diameter and hence equal in area to $1/100$ th of the area of the projection is of exceptional convenience for working with percentages.

One simple type of template is made by inscribing a circle 2 cm. in diameter on a small sheet of celluloid or cardboard and cutting out the circle (Fig. 7A). If only relatively few poles have been plotted, templates with areas equal to 2, 3, 4, etc. per cent of the projection can be used if desired, but the 1 per cent counter will usually be found satisfactory.

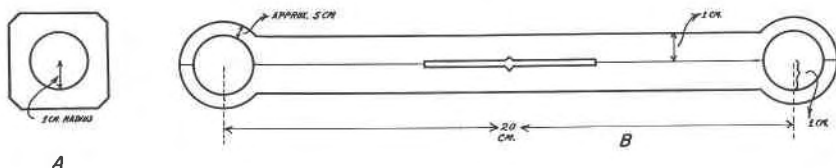

FIG. 7. Counting templates.

A. Small one per cent template.

B. One per cent perimeter counter.

For determining percentage distributions on and near the circumference of the diagram a perimeter counter spanning the 20 cm. circle is used. This device can be cut from a 3×23 cm. strip of celluloid. A fine line is inscribed down the middle of the strip. Toward each end, 10 cm. from the center, circles 2 cm. in diameter are inscribed and the discs punched out. Along the central line, for 3 or 4 cm. on both sides of the middle point, a narrow strip approximately 2 mm. wide is cut away. A notch is then cut at the middle point so that the counter can be placed over a pin and rotated freely (Fig. 7B).

Assembly: The sheet of coordinate paper is fastened to the drawing board. Over this the collective diagram is placed and centered, near the middle of the sheet, over one of the intersections of the heavy centimeter lines. For simplicity the collective diagram may be turned so that its index mark lies at the south point, i.e., nearest the observer. A sheet of tracing paper, upon which a circle 20 cm. in diameter has been inscribed, is laid over the collective diagram. The center of the circle of the uppermost sheet is brought into coincidence with the center of the collective diagram. A pin, later used when intersections near the circumference are numbered, is put through the center of the assembly. An index mark is placed on the circumference of the circle on the topmost sheet over the index on the collective diagram beneath. The properly oriented assembly is securely fastened down.

Counting the percentage distribution of poles: There are three variations in the method of counting depending upon which part of the contour diagram is being prepared.

A. *When the area enclosed by the template lies entirely within the circumference of the contour diagram circle*

The small template is centered over an intersection of the heavy centimeter lines. This is easily done by placing it so that any four of the heavy lines, defining a 2×2 cm. square, are tangent to the template

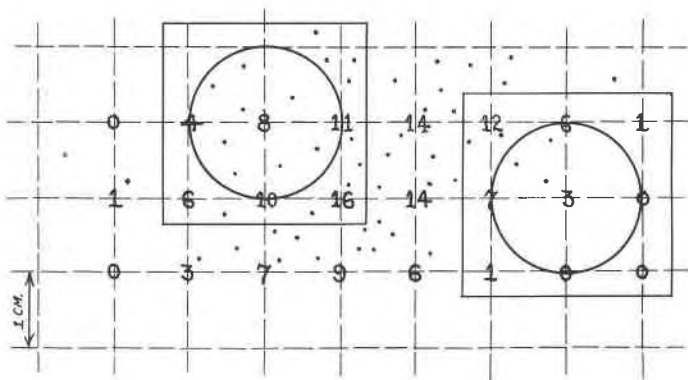

FIG. 8. Diagram illustrating the use of the counter for determining the number of poles per unit of area.

circle. Count the number of points on the collective diagram which lie within the area exposed in the template circle. Write down this number in pencil over the intersection point at the center of the template circle (Fig. 8). This procedure is followed until all centimeter intersection points, whose position is such that the area included in the template lies entirely within the net circumference, are numbered.

B. When part of the area exposed in the counting template lies outside the circumference

Case 1. The intersection point of the centimeter lines lies within the circumference, but close to the margin

The perimeter counter is mounted over the pin and swung until one of the circles is centered over the intersection in question (Fig. 9). Regardless of where the center of the opposite counter circle lies, the num-

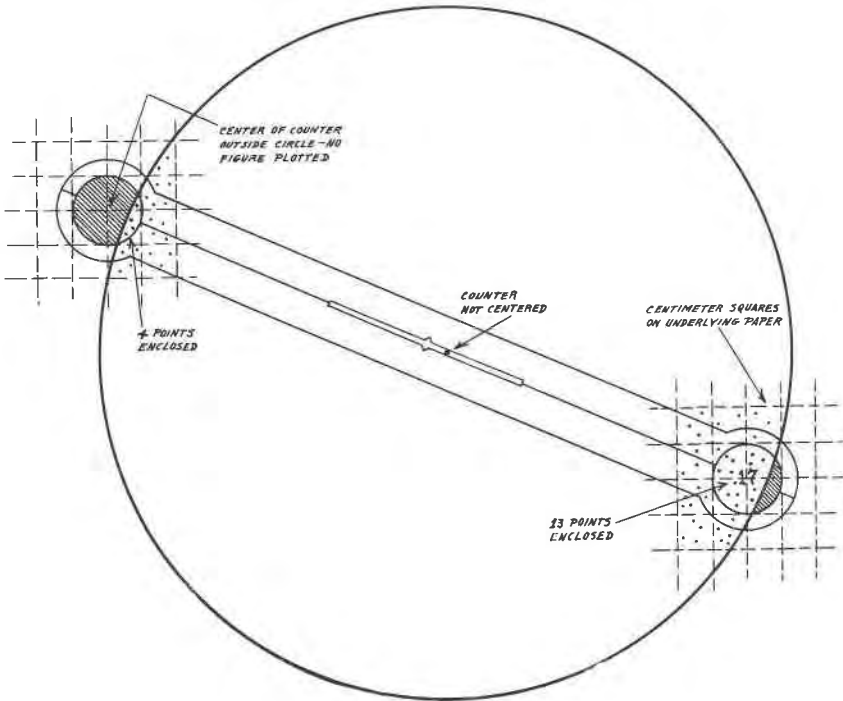

FIG. 9. Diagram illustrating the method of counting when some part of the area within the counter lies outside the circumference although the intersection lies inside.

ber of points in *both* template circles is determined. The points in each circle are then added together, and the figure representing their sum is set down at the center of the circle first adjusted. When one circle has been centered, the other may be centered over an intersection outside the diagram. No figures need be set down at these exterior intersections as they are not required for contouring.

Case 2. Plotting figures on the circumference of the diagram

Mark off a series of points 1 cm. apart around the circumference of the diagram for at least 180 degrees. Place the perimeter counter over the pin, center it by means of the notches and keep it centered during the following operations. Rotate the counter until a circle is centered over one of the centimeter marks (Fig. 10). Count the number of points in both circles and add them together. On the circumference, at the centers of the two circles of the counter, plot the total number of grains.

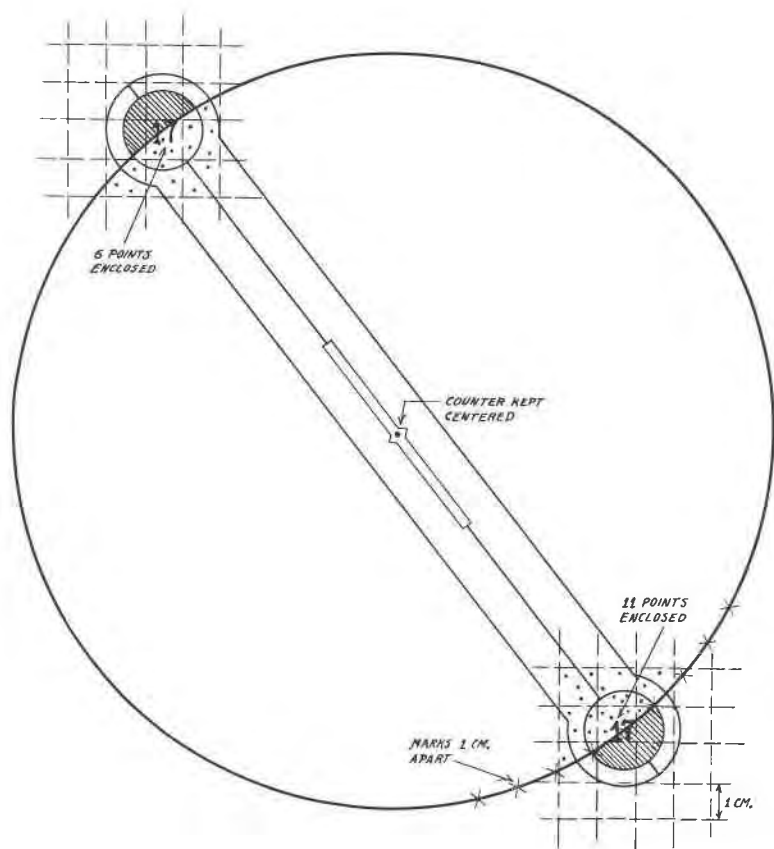

FIG. 10. Diagram illustrating the method of counting along the circumference of the circle.

Table of percentages

When distribution figures have been plotted at each intersection within the diagram, and at points laid off on the circumference, a table of percentages is drawn up. The number of grains equivalent to 1, 2, 3, 4, etc.,

per cent of the total number measured is calculated. The table is carried out to a percentage equivalent to the largest, or just less than the largest, figure plotted either at an intersection or on the circumference. The figures for the number of grains corresponding to a given percentage of the total are rounded off to the nearest whole number and are then called contour numbers. As an example, we may take a set of figures derived by measurement of 452 quartz axes in a quartz biotite-schist from a section cut normal to the "b" axis. The maximum concentration of poles per unit of area, as indicated by the highest figure determined with the 1 per cent counter was 43. The table is therefore carried out to 9 per cent.

TOTAL NUMBER OF GRAINS MEASURED 452

Per Cent of Grains Measured	Number of Grains	Contour Numbers
0.5	2.26	2
1	4.52	5
2	9.04	9
3	13.56	14
4	18.08	18
5	22.60	23
6	27.12	27
7	31.64	32
8	36.16	36
9	40.68	41

Contours could and may be drawn through all points representing each percentage from 0.5 to 9. But to obtain sufficient detail and clarity, it may not be necessary to draw contours on each per cent. Hence, in the case cited, 2 per cent intervals were used above 5 per cent.

Contouring

Contours are drawn through all points on the diagram with a pole density figure equal to one of the contour numbers. The highest contour is drawn first, i.e., begin by connecting points bearing the largest contour number. Locate the point bearing the highest figure plotted with the counter. Refer to the table and note whether this number is, by chance, equal to the largest contour number. If the two are identical, a contour enclosing this point is drawn. Usually the highest number on the diagram will exceed the largest contour number. For greater accuracy in finding the course of this contour, which defines the maximum, it is advisable to interpolate with the counting template in the area about this highest point.

The number plotted at any intersection point may be the same as a contour number. In such a case the contour passes through the point. Commonly the figure at the intersection is not the same as the contour number. Then the contour passes by the intersection, its proximity depending on the figures adjacent to the intersection in question. The contour is interpolated so as to pass between surrounding intersection points at a distance proportional to the difference between the contour number and the figures at adjacent points. To remove uncertainty as to the course of a contour, the small counting template is centered over intermediate points around the centimeter line intersections (Fig. 11). Figures should first be interpolated at the centers of each centimeter square. Usually in this way the necessary degree of accuracy will be obtained without further interpolation. Any amount of detail desired may be secured by additional interpolation. Particular care should be taken with isolated areas on the diagram, and interpolation carried out until these portions are well demarcated.

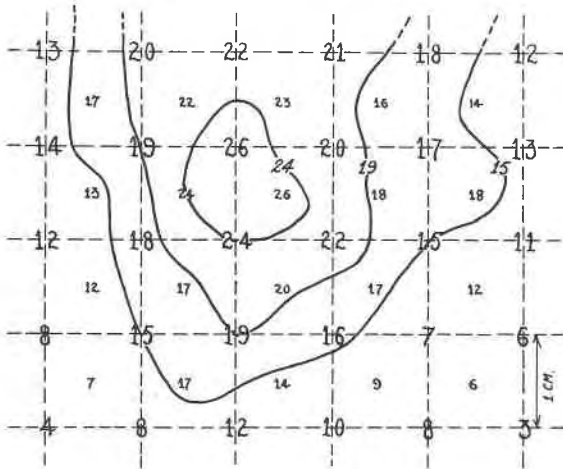

FIG. 11. Sketch illustrating method of drawing contours. Small figures have been interpolated at the center of each centimeter square.

If a contour line intersects the circumference of the diagram, its continuation begins from the point lying diametrically opposite the place of intersection (Fig. 12A). This point is readily found by setting the perimeter counter over the pin and using the center line as a guide.

If a contour number lies exactly on the circumference of the diagram, it is sometimes permissible to draw the contour close to the number rather than to proceed all the way to the margin. Such treatment de-

pend, however, upon the distribution of other contour numbers of the same value and upon the subsequent course of the contour. As seen in Fig. 12B, the No. 7 contour has not been continued to the margin. In the situation indicated it may be drawn so that it approaches the circumference quite closely and then turns away. This prevents small insignificant patches, which disturb continuity, from appearing on the opposite side of the diagram.

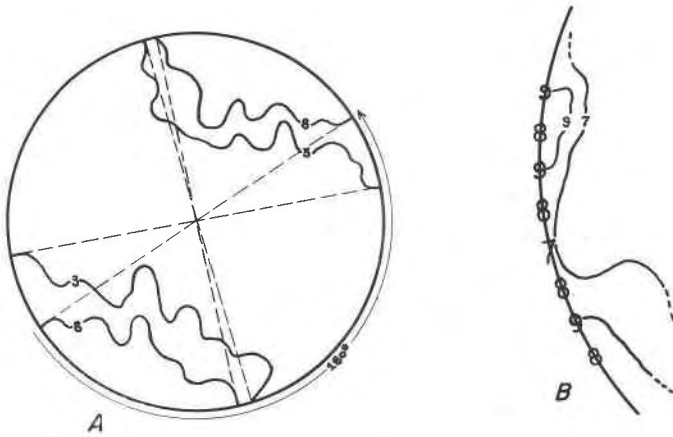

FIG. 12. A. Diagram showing how to locate the continuation of a contour, which has been drawn out to the circumference, by locating the point diametrically opposite the place of intersection.

B. Sketch indicating how the contour line (No. 7 in this instance) may pass close to the circumference to prevent appearance of insignificant patches on opposite side of diagram.

When all contours are drawn, the maxima, which are the areas containing the highest concentration of poles, are marked in solid black. Additional symbols may be applied but in many respects their use is disadvantageous, except, perhaps, if the diagram is being prepared for publication. Even clean-cut symbols, when crowded, or when used in restricted areas, may partially destroy legibility. It is then difficult to rotate the diagram, for such extraneous material on the drawing may cause confusion.

ROTATION OF THE DIAGRAM

For purposes of reference and comparison one may rotate the contour diagram so that some other reference axis than that normal to which the section was cut, will stand vertical and emerge at the center of the projection. After rotation the effect and distribution of contours, which would have resulted if a section normal to this other reference axis

had been measured, can be approximated. If a thin section normal to "b" is measured, one may wish to see what pattern would have been derived had a section perpendicular to "a" been examined. By rotation of the contour diagram of the thin section normal to "b" through 90 degrees

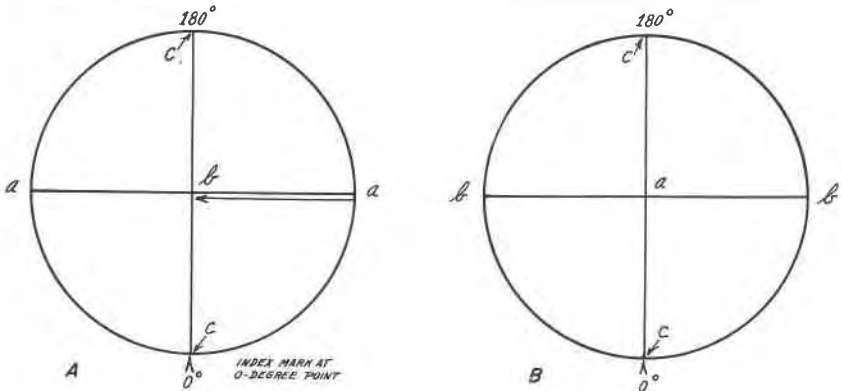

FIG. 13. Rotating the diagram so that the "a" axis is perpendicular. A. The "b" axis is perpendicular to the projection plane, "c" being the axis of rotation.

B. Position of axes after rotation of 90 degrees bringing "a" perpendicular.

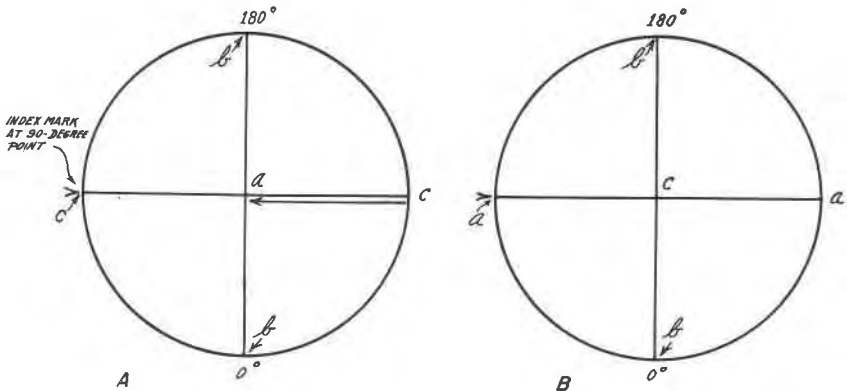

FIG. 14. Rotating the diagram so that the "c" axis is perpendicular. A. The "a" axis stands perpendicular to the projection plane; the "b" axis, in this case, is the axis of rotation.

B. Position of axes after rotation of 90 degrees to bring "c" perpendicular.

about the reference axis "c," the "a" axis can be brought perpendicular to the projection plane. The selection of the correct reference axis for bringing either of the other two reference axes vertical requires clear visualization of the geometric relationships of the measured section with respect to the reference lines established on the hand specimen in the very beginning.

On the equal-area projection rotation can be readily performed because all the great circles projected upon it, with the exception of the 90–270 degree meridian, intersect the equatorial plane of the reference sphere along the same diameter. The trace of this diameter on the projection is the north-south (0–180°) meridian. This 0–180 degree line is, then, at all times the rotation axis of the projection. *The reference axis about which points on the contour diagram are rotated must coincide with this north-south meridian.*

Assembly: Center the contour diagram over the net. Over this center a sheet of tracing paper upon which the customary 20 cm. diameter circle has been drawn. On this upper sheet place an index mark over the index mark on the contour diagram beneath. Fasten the two sheets together so that they may be moved about without shifting relative to one another. Then orient the diagram beneath so that the proper reference axis coincides with the north-south meridian. Fasten the assembly down in this position. The index mark on the original diagram may now coincide with the 0-degree point on the net circumference, or it may lie 90 degrees therefrom. The position of the index mark depends upon which section was measured and which one of the axes it is required to bring vertical, i.e., normal to the projection plane (See Figs. 13 and 14).

Rotation: Select a point on a contour of the original diagram. Along the arc of the vertical small circle lying beneath the selected point count off, in the proper direction, the number of degrees of rotation necessary to bring the required reference axis into coincidence with the vertical axis of the reference sphere, i.e., with the center of the net (Fig. 15A). This process is tantamount to swinging an axis, which passes through the center of the reference sphere, along the surface of the lower hemisphere. During such movement, as long as the axis of rotation coincides with the north-south meridian of the net, the pole will move along the arc of a vertical small circle. If the section measured was cut truly normal to the reference axis, a rotation of 90 degrees is required to bring either of the other two reference axes vertical. If the section was not cut normal to the reference axis, rotation through a varying number of degrees will be required, depending on the individual case. When rotation through the necessary number of degrees is completed place a point on the upper sheet of tracing paper directly over the arc along which the point was carried. Also on the upper sheet, over the original contour, at the point just rotated, place a small cross to avoid repetition. In the same manner rotate additional points on the same contour until a sufficient number have been plotted so that the contour can be accurately delineated in its new position. Connect the points rotated and draw in the contour.

It often happens that before a point has been rotated the necessary

number of degrees the circumference of the net is reached. With a straight-edge, or by counting off 180 degrees, find the point on the circumference exactly opposite. The contour point is then rotated the remainder of the required distance along the arc of the vertical small circle, intersecting the circumference at this diametrically opposite point (Fig. 15B).

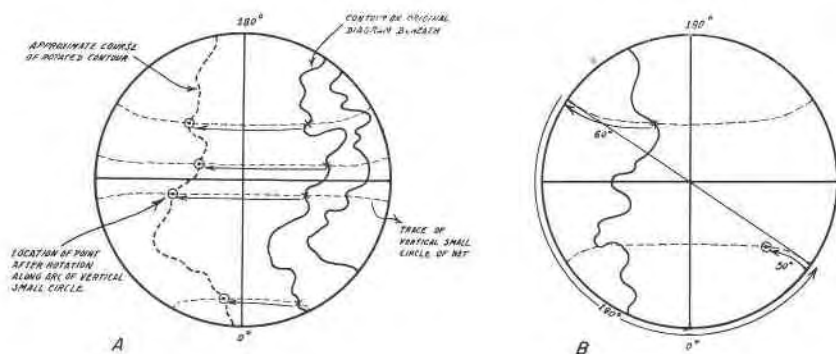

FIG. 15. Rotation of diagram. A. Figure illustrating the rotation of points along the arcs of vertical small circles on the net. In this case the rotated point does not reach the circumference of the diagram.

B. Diagram illustrating the method of locating the vertical small circle along which to continue rotation after a point has been rotated to the circumference of the net. A rotation of 90 degrees is assumed.

In general it is best to rotate all the points necessary to define one contour line before beginning another. When connecting points to draw the rotated contour, it will often be found that the latter intersects the circumference. The continuation of the rotated contour begins at the point diametrically opposite the intersection point, just as was the case when the contour was originally drawn.

MEASUREMENT OF TWINNING AND CLEAVAGE PLANES

Measurement of twinning lamellae in calcite

The relatively frequent development of gliding planes and twinning lamellae in calcite which has been subjected to deformation is well known. Under stress, twinning lamellae parallel to definite crystallographic planes are readily developed. According to Sander the most important type of grain deformation in calcite is translation and twinning parallel to the faces of the obtuse negative rhombohedron "e" (01 $\bar{1}$ 2). Although occasionally detected, twinning parallel to the faces of the fundamental form (10 $\bar{1}$ 1) is relatively rare. It may occur in 1 or 2 per

cent, but has never been noted in more than 11 per cent, of all cases.²⁵ Thin section crystals cut normal, or nearly normal, to the optic axis of a grain of calcite may show twinning lamellae developed in three directions. Ordinarily, however, they are found developed only in one or two directions in the crystal under observation.

Procedure: If the poles of the twinning lamellae in all crystals of calcite in a thin section are to be measured, there is no need for selection. But where lamellae are not present in all cases and measurement of them is definitely selective, those crystals with lamellae can be located easier if the nicols are crossed during preliminary searching. But in any case when the orientation of the twinning plane is actually determined the nicols are uncrossed. In the following procedure it is assumed that the plane of vibration of the polarizer is north-south. As before, the crystal is centered, or at least approximately so, and the horizontal axes of the universal stage are set at zero in the beginning.

1. Rotate the crystal on A_1 until the trace of the lamella is parallel to the east-west crosshair.

2. Rotate on A_4 until the lamella is reduced to the thinnest, sharpest line possible.

When the crystal has been brought into this position the twinning plane stands vertical with respect to the universal stage and is parallel to the microscope axis. Its pole can now be plotted.

Plotting the pole of the normal to the twinning plane: Inscribe a circle 20 cm. in diameter on a piece of tracing paper; center this circle over the Schmidt net; and fasten the sheet in place over the pin. Place the index mark on the circumference.

1. Rotate the tracing paper until the index mark lies over the figure on the net circumference corresponding to the A_1 reading.

2. On the north-south (0-180 degree) meridian of the net plot the pole from the reading obtained on A_4 .

When the drum of A_4 is rotated toward the observer, so that the reading was, let us say, 330 degrees, count toward the center from the 180 degree point on the net circumference, and find the figure corresponding to the A_4 reading. Plot the pole at this point on the north-south meridian (Fig. 16). If the drum of A_4 is turned away from the observer, the pole is located by counting along the north-south meridian from the south (0-degree) point toward the center of the net.

While at Innsbruck the writer was instructed to measure these lamellae by bringing the trace parallel to the east-west crosshair in the manner just described. The morphological relationship between the fundamental rhombohedron " r " ($10\bar{1}1$) and the rhombohedron " e " is

²⁵ Sander, B., *opus cit.*, p. 202.

such that when working with the lamellae in the east-west position the difference in index of refraction between the "e" ray of calcite (1.486) and that of the segments (1.64 approx.) should be taken into consideration. For highest accuracy in plotting, the special scale used when plotting the pole of the optic axis of calcite after the crystal is brought into the equatorial position, should also be employed if such accuracy is de-

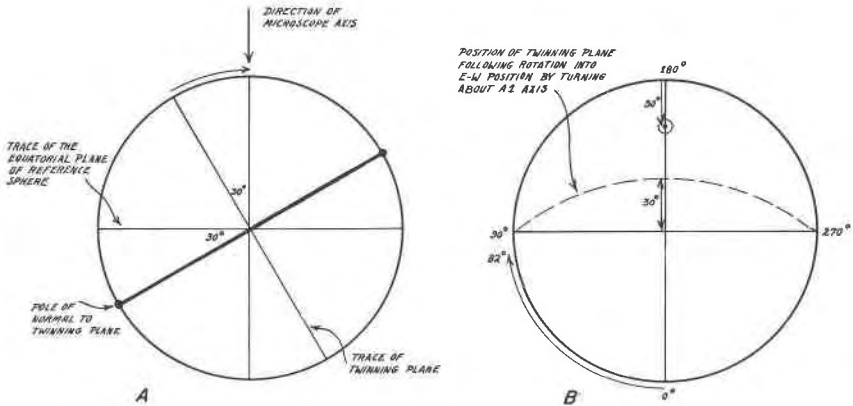

FIG. 16. Plotting poles of calcite lamellae; coordinate A_1 82° , A_4 30° . A. Relationship of the normal to the twinning plane and the reference sphere.

B. Tracing paper rotated until the index lies at 82° point. Pole plotted on N-S meridian 30° in from the circumference.

manded. In such a case the corrections for the different angles of inclination on A_4 should be laid off on the north-south meridian. Ordinarily such precautions are not required for routine measurements. An alternative method is to rotate the trace of the lamella parallel to the north-south crosshair. But if this practice is followed the relief of a grain will be relatively less, and as a rule the position of rotation at which the trace forms the finest possible line cannot be detected so easily.

In general, whenever the optic axes of calcite are measured, the lamellae which are present should be measured at the same time. One plots the pole of the optic axis first and assigns a number to this pole. The poles of the lamellae in the crystal are then numbered correspondingly. For example, if the pole were number 6, then $6'$, $6''$, $6'''$ could represent the respective lamellae measured.

Measurement of mica

Muscovite and biotite are measured in the same manner as calcite lamellae by rotation on A_1 until the trace of the basal cleavage lies parallel to the east-west crosshair. Then by rotation on A_4 the cleavage trace is reduced to the finest possible hairline. The stage should be ro-

tated on A_4 both toward and away from the observer. It will then be seen that the trace of the cleavage plane widens notably on both sides of the vertical position and the correct fine adjustment can be determined more accurately. The poles of the normals to the cleavage planes are plotted in the same manner as the poles of calcite lamellae.

Sometimes the orientation of the mica flakes and the plane of the thin section are such that basal sections are obtained. If we are measuring a biotite which is not too dark in color so that extinctions can be observed, the pole of the optic axis can be determined by the same methods used for measurement of the uniaxial minerals. Biotite can be treated in this way because, for practical purposes, the acute bisectrix X may be considered to stand perpendicular to (001).

DIAGRAMS SHOWING THE ORIENTATION OF ELONGATE, PRISMATIC AND ACICULAR MINERALS

One may wish to determine the orientation of elongate crystals which lie approximately in a well-marked structural plane. The minerals best suited to treatment by the method given here are those which are frequently prismatic or acicular in habit, as hornblende, apatite or tourmaline. For these diagrams the optical orientation of a grain is not specifically measured, for only the azimuths of the elongate crystals are determined. A "*garbenschiefer*" containing abundant hornblende needles is an example of a rock amenable to investigation of this nature. The method can, however, be used for elongated crystals of quartz, calcite, and sections of mica cut nearly normal to the basal plane. In general, the procedure is adapted to all types of minerals where in-equidimensional form and idiomorphic tendency are pronounced.

Assembly: A circle 20 cm. in diameter is drawn on a sheet of tracing paper and an index mark placed on the circumference. The tracing paper is superposed and centered on the Schmidt net, and the index mark brought to the 0-degree point on the circumference.

Procedure: Each crystal of the selected mineral is brought to the intersection of the crosshairs by moving the thin section along the guiding edge of the sledge. By turning about the A_1 axis (horizontal axes set at zero), the crystal is rotated until the cleavage trace (as with hornblende or mica) or the long axis (as with apatite prisms or tourmaline needles) is parallel to one of the crosshairs.

For a given set of measurements either crosshair can be used as a reference line, but no change should ever be made during the measurements. It will be assumed here that the north-south crosshair is used. Only one-half of the projection is required for plotting and when measuring from the north-south crosshair only the lower semicircle on the tracing paper is utilized. By a series of traverses every grain of the

selected mineral encountered is measured and its azimuth plotted until a sufficient number for statistical purposes have been secured.

Plotting: Rotate the tracing paper until the index mark lies at the point on the net circumference corresponding to the reading of the A_1 circle. Over the 0-degree mark on the net, using a very fine pen, place a short line on the inside of the circumference (Fig. 17A). To avoid con-

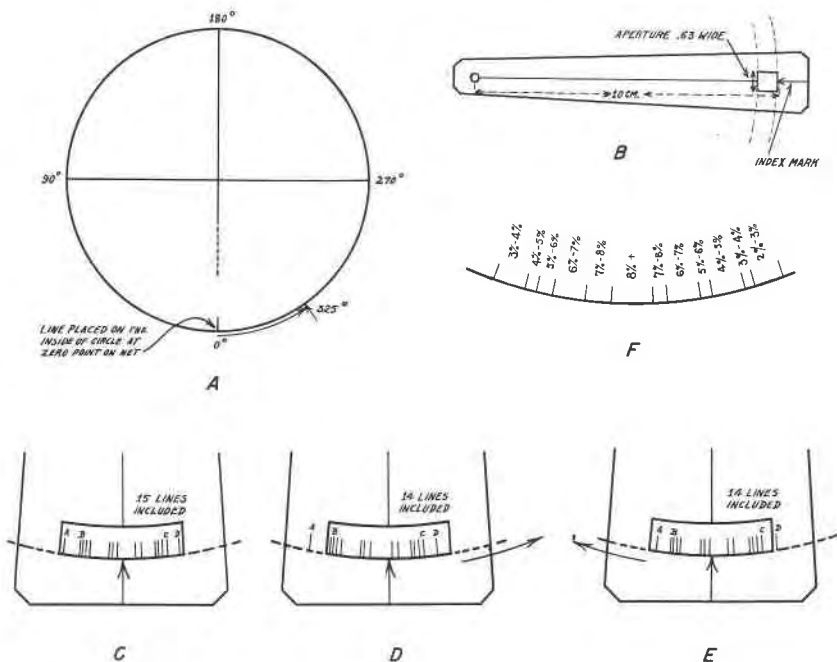

FIG. 17. A. Diagram illustrating the method of plotting azimuths.

B. One per cent template used for counting percentages of grains with various azimuths.

C, D, E. Sketches showing successive steps in determining the length of arc containing a given percentage of lines.

F. Appearance of diagram after arcs have been determined with counting template.

fusion bring the index mark of the tracing paper back to the 0-degree mark on the net after plotting the line. Sometimes the crystals will have such conspicuous orientation that many of these short lines will overlap. One can then place a figure above the line indicating the number of grains with this same azimuth.

Making the diagram

When a sufficient number of grains are plotted the percentage of grains having various azimuths can be graphically represented. A seg-

ment of a circle equal in length to 1/100th of the circumference of the net is usually taken as a reference unit. Since the diameter of the net is 20 cm. a segment representing 1/100th of the circumference will be 0.63 cm. long. For measuring the segment intercepts a template is used. A strip of celluloid approximately 2 cm. wide and 12 cm. long is obtained and a line scribed down the middle. On this line, about 1 cm. from one end make a small puncture. Ten centimeters from this point an arc is drawn across the strip. Approximately 1 cm. above this arc another is lightly scribed. From the point where the lower arc crosses the median line of the strip a distance of 0.315 cm. is laid off on both sides of the point. Celluloid is then cut away from between the two arcs leaving an aperture which exposes a segment equal to 1 per cent of the net circumference (Fig. 17B).

Assembly: The tracing paper on which the grain azimuths have been plotted is fastened to a drawing board, and over this another sheet of transparent paper with the usual circle 20 cm. in diameter is placed. The two sheets are firmly fastened together. An index mark is placed on the upper sheet exactly over the index on the diagram beneath. The celluloid template is fastened at the center of the circle with a pin. The template should now swing freely and the bottom of the aperture should be flush with the circumference of the circle.

Table of Percentages: A table of percentages indicating the number of grains representing different amounts of the total measured is drawn up. This table is carried out until the maximum number of grains included in the aperture at the point of greatest concentration of lines is just exceeded. Let us assume that the azimuths of 174 grains have been measured and that the largest number of grains included within the 1 per cent template is found to be 15. Nine per cent of the total grains measured exceeds by one the largest number included in the aperture (see table).

Per Cent of Grains Measured	Number of Grains	Segment Numbers
1	1.74	2 grains
2	3.48	3 grains
3	5.22	5 grains
4	6.96	7 grains
5	8.70	9 grains
6	10.44	10 grains
7	12.18	12 grains
8	13.92	14 grains
9	15.66	16 grains

Counting: The template is first swung to the point on the circumference showing the greatest concentration of lines. In the example cited the template is swung until 15 grains, equal to 8+ per cent of the total, are included (Fig. 17C). The length of the arc containing 8 or more per cent of the total number of lines must now be found. The template is moved, right or left, from the area of maximum concentration, until the aperture includes just 14 grains (Fig. 17D). When exactly the number of lines specified by this lower limit are included, a mark is set on the circumference of the circle *at the point where the index of the aperture lies*. The template is then swung in the opposite direction until 14 lines are again included in the aperture and another mark placed at the aperture index (Fig. 17E).

The segment defined by these two lines is a portion of the circle having 14 or more lines and 8+ per cent of all grains measured lie with their long axes within the azimuth range indicated. Counting is continued by swinging the template until the aperture includes the number of lines indicated by the segment number of the next lower percentage. In our case this figure is 12, representing a number of grains equivalent to 7 per cent of the whole. Counting and dividing off of the circumference continues in this manner until each percentage is considered.

The lines made on the circumference should be at least 5 mm. long and the areas between adjacent lines should be numbered with the corresponding percentages represented (Fig. 17F). When counting is completed symbols may be used to designate different percentages and the variation in frequency and orientation. If the lines are very much congested it may be advisable to use a set of percentages including a larger number of grains per unit. Units of from 0-2 per cent, 2-4 per cent, 4-6 per cent may then be found more satisfactory. If relatively few grains are measured the plotted lines may be too sparse for working conveniently with the 1 per cent aperture. In such case templates with apertures of 1.26 cm (2%) or 1.89 cm. (3%) or even larger may be employed.

ACKNOWLEDGMENT

The author wishes to acknowledge the assistance rendered by the trustees of Columbia University who awarded him the William Bayard Cutting Traveling Fellowship in April 1936. With the help of funds from this source several months were spent in Innsbruck, Austria, in the winter of 1936-37.