

AN AMPLIFIER FOR DIFFERENTIAL THERMAL ANALYSIS*

CARL W. BECK,

*Department of Geology, University of New Mexico,
Albuquerque, New Mexico.*

ABSTRACT

An amplifier to be used with pen and ink recorders in the differential thermal analysis studies of minerals is described. The fundamentals of the amplifier are: (1) conversion of direct voltage to alternating voltage, (2) amplification of the alternating voltage, and (3) rectification of the amplified alternating voltage to direct voltage.

Curves for 14 analyzed minerals recorded with a pen and ink recorder are compared with photographically recorded curves obtained by Speil (1945) on the same minerals.

INTRODUCTION

The method of differential thermal analysis is a recognized and useful technique for the study of certain minerals or mineral groups that undergo either physical or chemical changes, or both, when heated. The theory of differential thermal analysis has been explained and the technique and apparatus described adequately by many workers in the field, such as Berkelhamer (1945), Grim and Bradley (1940), Grim and Rowland (1942), Hendricks et al. (1946), Jourdain (1937), Kerr and Kulp (1948), Norton (1939 and 1940), Orcel and Caillère (1933), and Orcel (1935). The standard recorder for differential thermal analysis curves has been the photographic type well-described by most of the above authors. More recently workers in the field have turned to pen and ink recorders. Kerr and Kulp (1948) describe a multiple differential thermal analysis apparatus in which they use a Leeds and Northrup "speedomax" as the recorder. Commercial recorders do not possess a sensitivity great enough to detect small thermal reactions, so it becomes desirable in the thermal analyses of most minerals to increase the sensitivity. It is the purpose of this paper to describe an amplifier used successfully by the author in differential thermal analysis studies.

AMPLIFIER

It was desired by the author to use a pen and ink recorder in his differential thermal analysis studies. Several types of existing recorders could be adapted to the purpose, but an Esterline-Angus Graphic Ammeter was available and was used. The instrument is not sensitive enough without amplification to record the small potentials developed by thermo-

* Abridged from a Ph.D. thesis, "An Improved Method of Differential Thermal Analysis and Its Use in the Study of Natural Carbonates," Harvard University. Contribution from the Department of Mineralogy and Petrography, Harvard University, No. 315.

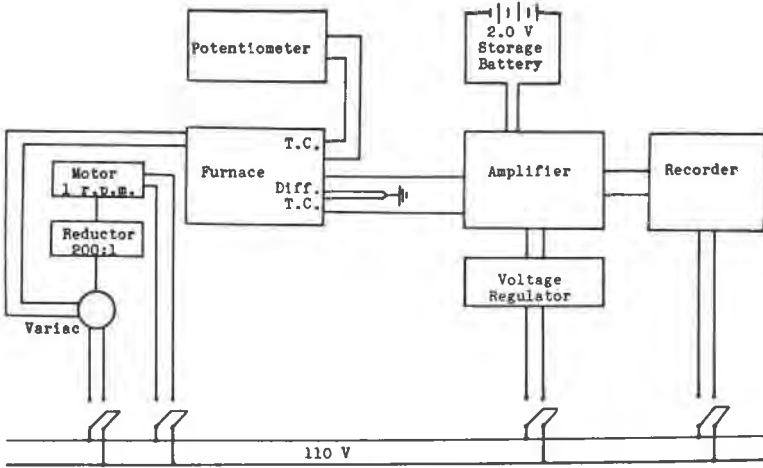
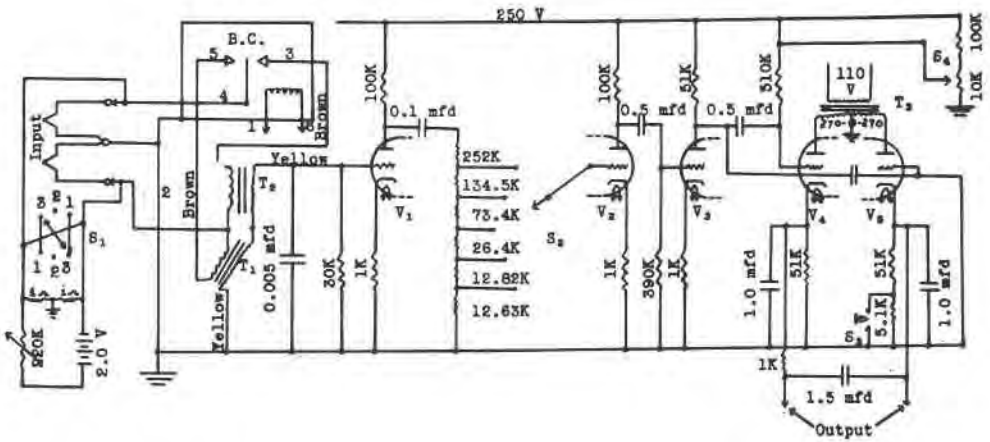

FIG. 1. Wiring diagram for differential thermal analysis apparatus.



- | | |
|--------------------------------------|---|
| B.C. = Brown Converter | $V_1, V_2 = 6SL7$ |
| S_1 = Calibration Switch | $V_3 = \frac{1}{2} 6SN7$ |
| S_2 = Sensitivity Switch | $V_4, V_5 = 6SN7$ |
| S_3 = Temperature Indicator Switch | $T_1, T_2 =$ Thordarson T-72A59 Transceiver Transformer |
| S_4 = Centering Switch | $T_3 =$ Acme B-4 Transformer, 110 V to 270-0-270 |

FIG. 2. Schematic diagram of amplifier.

couples during a thermal reaction in minerals. An Esterline-Angus recorder has an internal resistance of 1400 ohms and 0.5 milliamperes for half-scale deflection. Therefore, it requires 0.7 volts to get half-scale deflection. It was decided that an amplification of 10,000 on the most sensitive scale would give an appreciable peak for such weak reactions as the alpha-beta quartz inversion. Grim and Rowland (1942) say this inversion represents a differential temperature of about 2° C., and this is among the smallest energy changes to be recorded.

The diagram of the amplifier is shown in Fig. 2. Briefly, the basic principle of the amplifier is as follows: the direct voltage generated in the thermocouple by a thermal reaction is changed to alternating voltage; the alternating voltage is then amplified to a desired amount; and, finally, the amplified alternating voltage is rectified to direct voltage in order to operate the Esterline-Angus recorder. There are, therefore, three fundamental functions of this amplifier: (1) conversion, (2) amplification, and (3) rectification.

Conversion

The conversion of the direct voltage generated by the differential thermocouple to alternating current of proportional magnitude is accomplished by a Brown Converter (made by the Brown Instrument Company of Philadelphia) and the input transformers T_1 and T_2 (Fig. 2).

The converter is a flat reed that oscillates between the two contacts that are connected to the opposite ends of the primary winding on the input transformers, T_1 and T_2 . Consequently, as the reed moves from one contact to the other, an unbalanced direct voltage generated by a thermal reaction will cause a direct current to move at first in one direction through one half of the primary winding, and then in the opposite direction through the other half of the primary winding. Thus is generated an alternating current in the input transformers. The input transformers then induce an alternating voltage in the secondaries of the transformer. The reed will oscillate synchronously with the alternating supply voltage, so that the direct voltage generated by a thermal reaction becomes a certain number of cycles of alternating voltage in the secondaries, the number of cycles depending on the cycles of the alternating voltage supply. Usually the supply voltage is 60 cycle.

When a thermal reaction takes place in the analyzed sample the thermocouple therein imbedded becomes warmer or colder than the thermocouple in the inert sample, thus generating an unbalanced direct potential to be put across the converter. If the thermal reaction is exothermic the converter will induce in the input transformer secondary an alternating voltage wave whose positive areas correspond with the positive areas of

the alternating supply voltage, and the two voltages will be in phase. If the thermal reaction is endothermic the converter will induce in the input transformer secondary an alternating voltage wave whose positive areas correspond with the negative areas of the alternating supply voltage, and the two voltages will be 180° out of phase. This unbalance, following amplification and rectification, provides the means for deflecting the recording pen of the Esterline-Angus from the zero position.

In the apparatus used by the author, the input transformers, T_1 and T_2 , were set 20° off parallel to give linearity. The position of the transformer cores must be determined experimentally, and will vary for each pair of transformers. It is necessary to connect the two input transformers in correct phase. The color of the transformer leads in correct phase are given in the schematic diagram, Fig. 2.

The converter and T_1 and T_2 must be shielded and are thus enclosed in a metal box, and the box is grounded. All leads up to the grid of Stage 1 are covered with "spaghetti" and shielding, and the shielding is grounded. This complete grounding serves to minimize any alternating current pickup. In addition, it is desirable to have a non-inductive winding on the furnace used to heat samples during a differential thermal analysis run.

Amplification

The induced alternating voltage from the converter is increased in amplitude and power by the use of thermionic vacuum tubes. The current is passed through three stages of voltage amplification, two triodes of a 6SL7 tube and one triode of a 6SN7 tube. A sensitivity switch, S_2 (Fig. 2), is located between Stages 1 and 2. This adjustment consists of a potential divider by which only a portion of the output voltage from the amplifier Stage 1 is applied to the grid of Stage 2; it thus varies the amount of amplification. This selector switch is designed to pick off five different portions of the Stage 1 output voltage to give sensitivity Scales 1, 2, 3, 4, and 5 in the amplification ratio of 1, 2, 8, 20, and 40; that is, Scale 5 is 40 times as sensitive as Scale 1.

Rectification

The amplified alternating voltage must be rectified to direct voltage in order to operate the Esterline-angus recorder. Two stages of rectification are used in this amplifier. If a negative potential, instead of a positive potential, is applied to the plate, electrons will be forced back to the cathode and no plate current can flow. Thus if an alternating current is applied to the plate, plate current will flow only when the plate is positive. Hence, the current in the tube flows in one direction and is thus rectified to direct current.

List of material used in amplifier

- 1 Brown Converter, Brown Instrument Company, Philadelphia, Pennsylvania.
- 2 6SL7 thermionic vacuum tubes.
- 2 6SN7 thermionic vacuum tubes.
- 2 Thordarson T-72A59 Transceiver Transformer.
- 1 Acme B-4 Transformer, 110 V to 270-0-270.
- 1 Regulated Supply, Type 106 PA, 300 volts, Harvey Radio Laboratories, Inc., Cambridge Massachusetts.
- 1 Storage battery, 6.0 volts.

The author has tried, unsuccessfully, to amplify the potentials developed by thermal reactions by means of a direct current amplifier. A

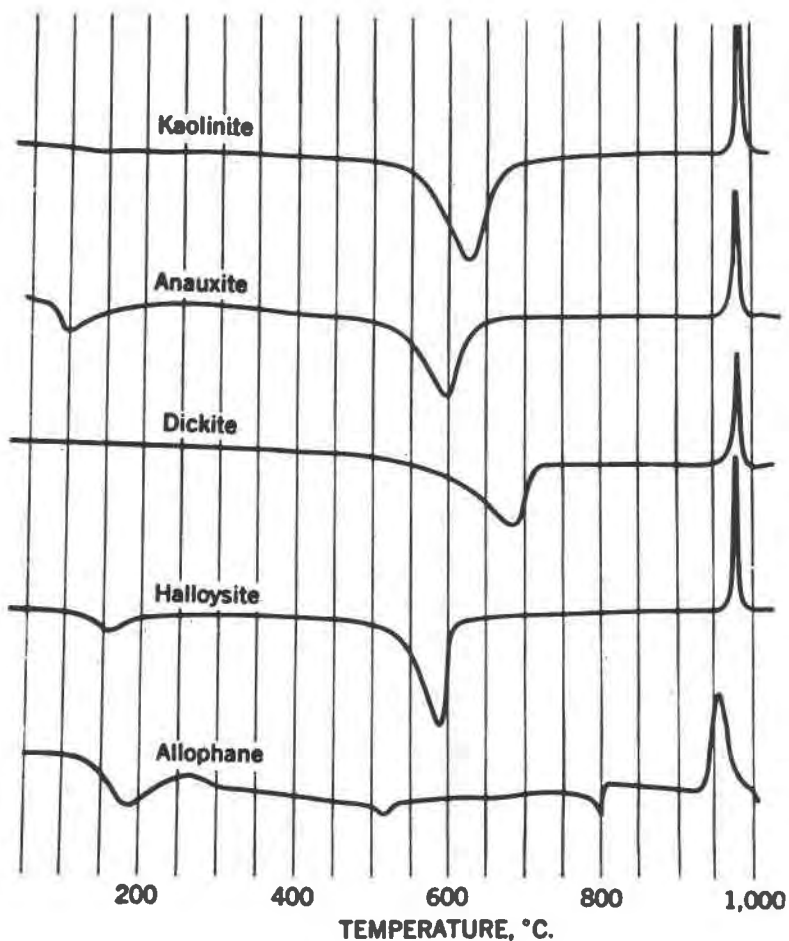

FIG. 3.—Thermal curves of kaolin minerals, scale C. (after Speil)

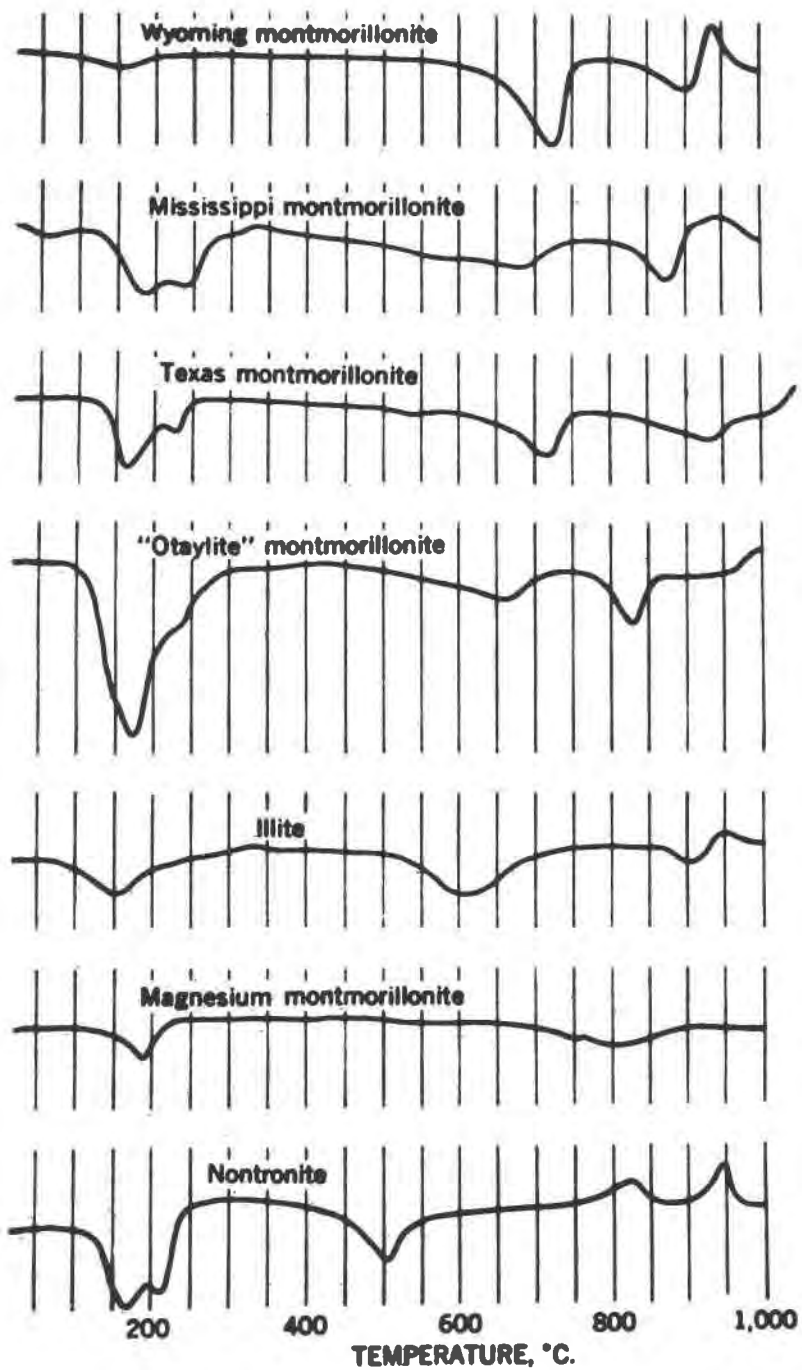

FIG. 4.—Thermal curves of three-layer lattice minerals, scale A. (after Speil)

three-stage amplifier of the ordinary push-pull circuit was constructed using 6SL7 tubes in Stages 1 and 2, and a 6SN7 tube in Stage 3. Stages 2 and 3 were satisfactory, but Stage 1 was unstable, exhibiting wander but no steady drift. 100% alternating current feedback was used on all stages, but no direct current feedback. The direct current amplifier was designed to operate in the linear region of the tube characteristics; that is,

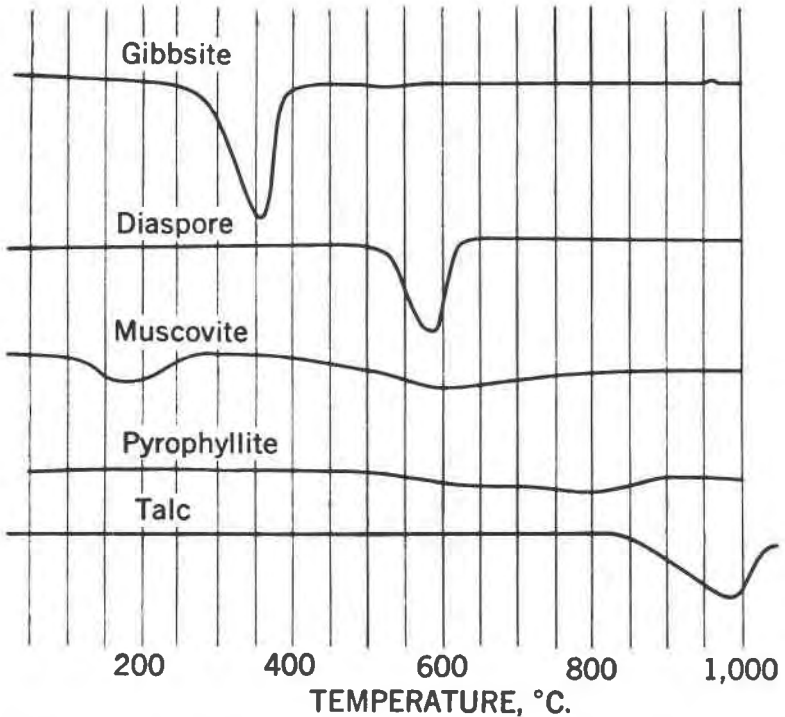

FIG. 5.—Miscellaneous thermal curves: gibbsite and diaspore, scale C; others, scale A. (after Speil)

an attempt was made to design with the plate currents no greater than 0.2 milliamperes per tube and direct coupling was used throughout. The last stage contained a balanced cathode follower for low impedance coupling to the Esterline-Angus recorder because of the high internal resistance of the recorder, namely, 1400 ohms. It is thought that tube leakage and instability of the circuit components of Stage 1 caused the trouble. The author believes it is possible to make a direct current amplifier, and experiments along this line are in progress.

METHOD OF OPERATION

The heating apparatus and sample holder used by the author were modeled after Berkelhamer (1945); the amplifier and recorder are described above. The differential thermal analysis runs were made according to the following scheme. Test samples were ground to minus 100-

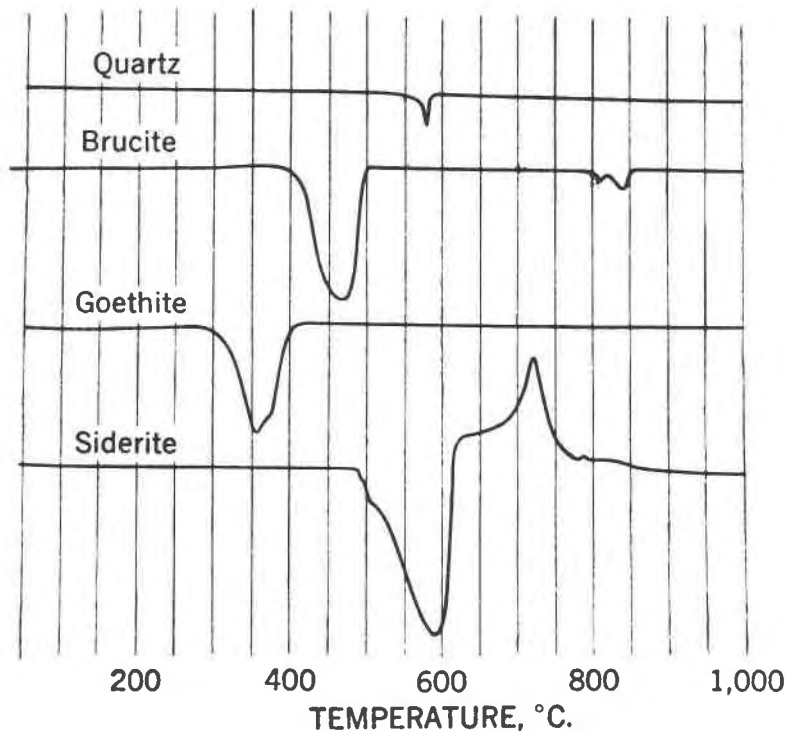

FIG. 6.—Miscellaneous thermal curves: quartz, scale A; others, scale C. (after Speil)

mesh, plus 200-mesh, and were kept in a desiccator over anhydrous CaCl_2 until ready for a run. They were not dried in an oven because it was felt that such drying would destroy adsorbed water on fine-grained minerals, and reduce or destroy the thermal reaction of minerals that lose structural water at a relatively low temperature. The weight of the sample was determined for each run. The material was packed carefully under and around the thermocouple wiring; the rest of the sample was packed above the thermocouple by means of a glass tamp. An attempt was made to pack each sample in the same manner.

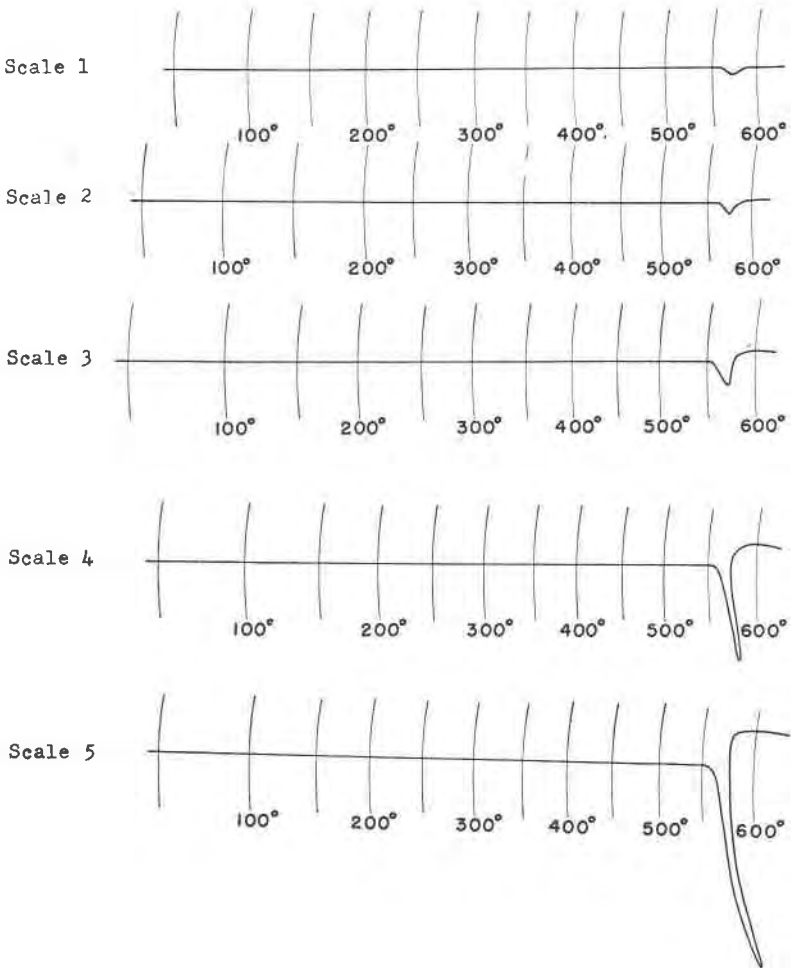

FIG. 7. Thermal curves of quartz showing relationship of scales 1-5.

The specimen holder and samples were covered with a nickel shield to eliminate direct radiation at the top of the samples. Then the furnace was brought forward so that the sample holder was held in the center of the furnace. The Variac was set at 35 volts and the furnace was warmed to 50° C. The sensitivity switch was set on the correct scale; the recorder was set at the zero position with the centering switch, S_4 ; and the instrument was calibrated by means of the calibration switch, S_1 , to be sure it was linear at the start of the run. When the furnace reached 50° C. the Variac drive and the Esterline-Angus recorder were turned on simultaneously. The extra current drawn by the Variac motor drive

caused a slight deflection of the recording pen and it was brought back to the zero point by S_4 . At 50° C. intervals up to 1000° C., small lines were put onto the thermal curve by the push switch, S_3 (Fig. 2). At 1000° C. the instrument was again calibrated to be sure it was linear at the end of a run. An average run took 83 minutes, and the deviation from average was never more than $1\frac{1}{2}$ minutes.

COMPARISON OF PHOTOGRAPHIC AND PEN AND INK METHODS

Eight samples of analyzed clay minerals and six samples of other analyzed minerals were obtained from Mr. Sidney Speil, Bureau of Mines Electrotechnical Laboratory, Norris, Tennessee. These had been used in his 1945 investigation. Reproductions of these curves appear in Figs. 3-6 and a listing of the characteristic thermal peaks and areas of most of these minerals appears in Table 3. A comparison of the deflection scales used by Speil is shown in Table 1.

TABLE 1. COMPARISON OF GALVANOMETER DEFLECTION SCALES

Scale	Average value of ΔT for 1 cm. deflection, $^\circ$ C
A.....	2.2
B.....	3.05
C.....	6.1

The differential thermal analysis curves of these same 14 samples recorded by the pen and ink method are shown in Figs. 8-12, and the characteristic thermal peaks and areas of these minerals are listed in Table 4. The comparison of the sensitivity of the different scales of this recorder is shown in Table 2.

TABLE 2. COMPARISON OF THE SENSITIVITY OF THE DIFFERENT SCALES
OF THE PEN AND INK RECORDER

Scale	Average value of ΔT for 1 cm. deflection, $^\circ$ C.
1.....	4.1
2.....	2.4
3.....	0.85
4.....	0.21
5.....	0.10

In comparing Speil's scales with the scales used in this report, it should be pointed out that Speil used platinum-platinum 10% rhodium for his thermojunctions and the author used chromel-alumel thermojunctions;

the latter develop about 4 times the voltage for the same temperature. Also, it seems to the author that the characteristic areas listed by Speil are too large by a factor of 10.

A graphic illustration of the relation of Scales 1-5 is shown in Fig. 7. These curves show the alpha-beta inversion of quartz.

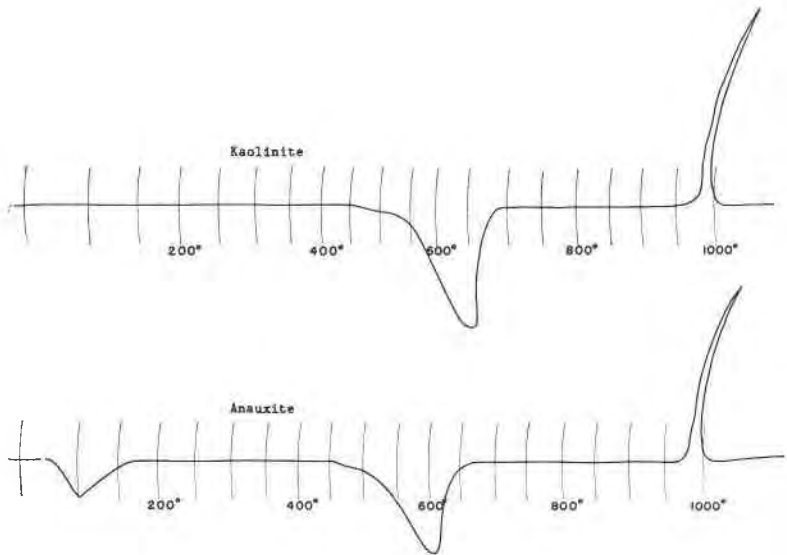

FIG. 8. Differential thermal analysis curves of kaolinite and anauxite, Scale 3.

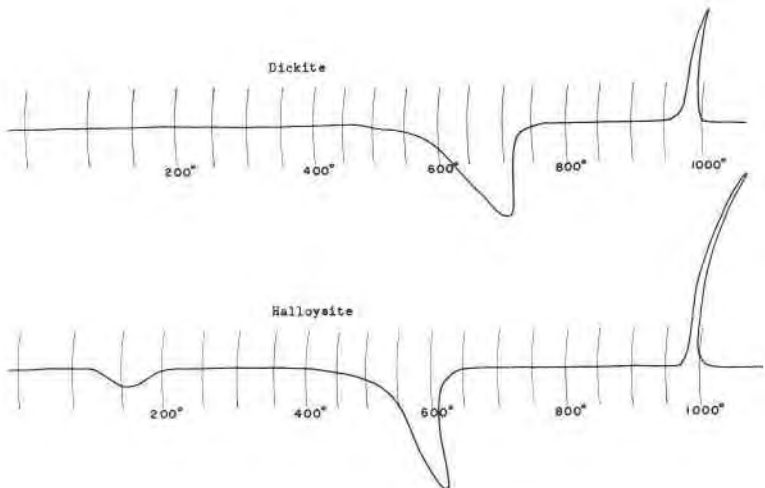

FIG. 9. Differential thermal analysis curves of dickite and halloysite, Scale 3.

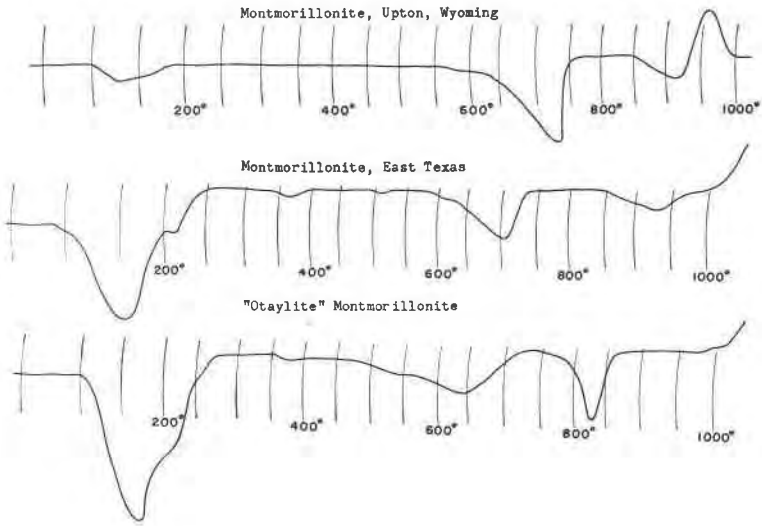

FIG. 10. Differential thermal analysis curves of montmorillonites, Scale 4.

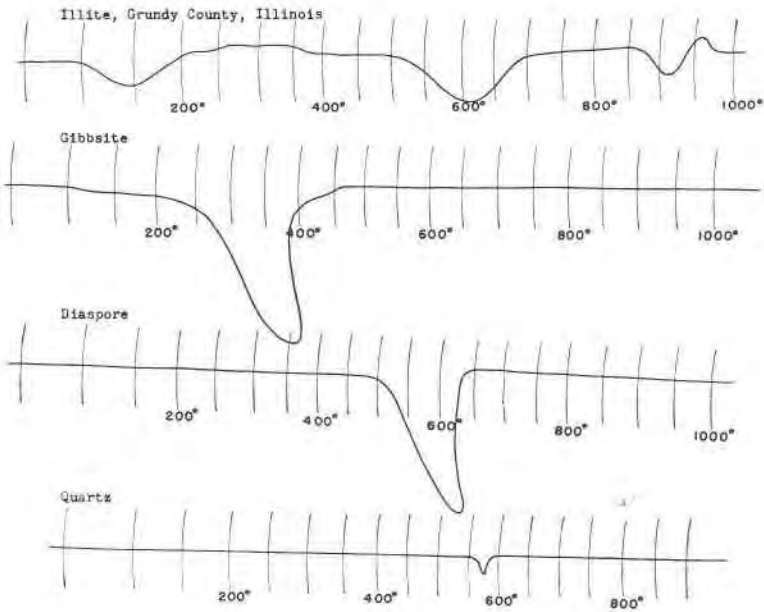

FIG. 11. Differential thermal analysis curves of illite (Scale 4), and gibbsite, diaspore, and quartz (Scale 3).

Examination of the thermal curves recorded by the two methods shows them to be in excellent agreement. Tables 3 and 4 show the thermal peaks to be essentially the same by both methods. There is a tendency for the peaks of the curves obtained on the pen and ink recorder to be at a slightly lower temperature. This is probably due to the fact that the pen and ink recorder reacts within a matter of a small fraction of a second after a thermal reaction takes place in the sample holder, while the

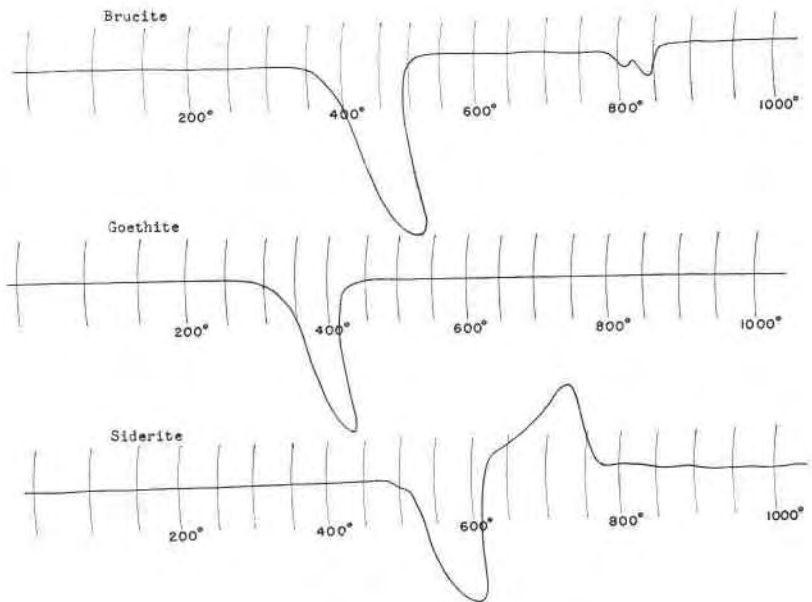

FIG. 12. Differential thermal analysis curves of brucite and goethite (Scale 3) and siderite (Scale 4).

Leeds and Northrup Type P galvanometer used in the photographic recorder has a time constant of 10–20 seconds. With the furnace rising at a rate of approximately 12° C. per minute this lag in the response of the galvanometer to the thermal reaction could push the peak temperature up several degrees. Two exceptions to this appear in the list of comparison runs: (1) diaspore has a peak temperature of 595° C. compared with 570° C. obtained by the photographic record, and (2) goethite has a peak temperature of 375° C. compared with 345° C. obtained by the photographic record. The author has no explanation for these two exceptions, but inspection of the curves obtained by Speil leads to the belief that the temperature should be higher for goethite and diaspore than

TABLE 3. CHARACTERISTIC THERMAL PEAKS OF MINERALS
(Speil, 1945, p. 21)

Mineral	Temperature, ° C.		Area, mm. ² Scale A
	Endothermic	Exothermic	
Kaolinite	620		6,100
		980	1,560
Anauxite	600		4,600
Dickite	690		4,900
Halloysite	175		indefinite
	585		4,250
Montmorillonite (Texas)	165-235		1,350
	725		1,070
	940		480
		1,020	indefinite
Illite	605		1,625
	900		merges
		940	merges
Gibbsite	365		8,400
Diaspore	570		5,200
Quartz	580		170
Brucite	465		7,000
Goethite	345		2,530
Siderite	585		10,300
		735	8,000

reported in Table 3. Re-runs of the diaspore and goethite gave check results for the pen and ink method.

ACKNOWLEDGMENT

This paper represents a portion of a differential thermal analysis doctoral problem. The author wishes to acknowledge the interest and encouragement shown by Professors E. S. Larsen, Jr., C. S. Hurlbut, Jr., and Clifford Frondel of the Department of Mineralogy and Petrography, Harvard University. He is especially indebted to Dr. Lee L. Davenport,

TABLE 4. CHARACTERISTIC THERMAL PEAKS AND AREAS OF COMPARISON
MINERALS, PEN AND INK RECORDER

Mineral	Temperature, ° C.		Area, mm. ²	Weight, gm.	Scale
	Endothermic	Exothermic			
Kaolinite	620		600	0.325	3
		985	103		
Anauxite	595		406	0.255	3
		985	106		
Dickite	690		470	0.385	3
		985	97		
Halloysite	150 585		53	0.360	3
		985	403 107		
Montmorillonite (Texas)	145-220 715 935		658	0.265	4
			205		
		1050	68 indefinite		
Montmorillonite (Wyoming)	140 725 920		57	0.340	4
			370		
		950	merges merges		
Montmorillonite "Otaylite"	165-200 650 825		920	0.350	4
			303		
		1030	160 indefinite		
Illite	600 910		140	0.320	4
		950	merges merges		
Gibbsite	350		455	0.345	3
Diaspore	595		510	0.430	3
Quartz	573		10	0.395	3
Brucite	460		730	0.360	3
Goethite	375		440	0.585	3
Siderite	585		615	0.540	2
		735	325		

TABLE 5. CHEMICAL ANALYSES OF COMPARISON MINERALS

	1	2	3	4	5	6	7
SiO ₂	45.20	64.26	44.91	43.74	64.29	60.26	51.19
Al ₂ O ₃	39.47	18.08	40.64	40.82	16.23	21.50	15.13
Fe ₂ O ₃	0.24	2.63	0.13	0.30	0.43	3.76	0.86
TiO ₂	1.53	2.20	0.18	0.00	0.18	0.22	0.16
CaO	0.18	0.65	0.33	0.00	1.15	0.00	1.00
MgO	0.10	0.86	0.17	0.00	2.17	2.50	7.19
Na ₂ O	—	—	—	—	0.74	2.67	0.73
K ₂ O	—	—	—	—	5.91	0.43	0.12
H ₂ O (—)	0.11	2.41	0.03	2.43	8.94	3.53	15.80
Ignition Loss	13.84	7.96	14.61	14.93	5.57	5.34	7.57
Total	100.67	99.05	101.00	102.22	100.25	100.21	99.75

Key to Table 5

1. Kaolinite, Gordon, Georgia.
 2. Anauxite, Franklin, North Carolina.
 3. Dickite, Chihuahua, Mexico.
 4. Halloysite, Eureka, Utah.
 5. Montmorillonite, East Texas.
 6. Montmorillonite, Upton, Wyoming.
 7. Montmorillonite ("otaylite"), Encinatas, California.
- H. R. Shell, analyst.

TABLE 5—Continued

	8	9	10	11	12	13	14
SiO ₂	52.17	3.45	0.5	98.24	1.19	—	FeCO ₃ =84.7%
Al ₂ O ₃	22.24	60.17	84.8	0.97	—	—	
Fe ₂ O ₃	6.16	2.72	0.1	0.00	0.96	83.63	MnCO ₃ =16.8
TiO ₂	0.82	2.46	0.00	—	—	—	
CaO	0.31	—	—	0.00	0.63	—	
MgO	2.42	—	—	0.00	64.78	—	
Na ₂ O	0.33	—	—	—	0.00	—	
K ₂ O	0.50	—	—	—	0.19	—	
H ₂ O (—)	3.08	—	—	0.03	0.08	0.46	
Ignition Loss	6.15	31.20	14.2	0.09	31.20	12.80	
Total	100.13	100.00	99.6	99.33	99.03	96.89	101.5

Key to Table 5—Continued

8. Illite, Grundy County, Illinois.
 9. Gibbsite, Arkansas (selected nodules).
 10. Diaspore, Chester, Massachusetts.
 11. Quartz, Potter's Flint.
 12. Brucite, Luning, Nevada.
 13. Goethite, Oregon Furnace, Maryland.
 14. Siderite, Lodenstein, Saxony.
- H. R. Shell, analyst.

University of Pittsburgh, and Mr. Robert Rogers, Massachusetts Institute of Technology, for technical advice in the construction of the amplifier. Mr. Sidney Speil of the Bureau of Mines Electrotechnical Laboratory, Norris, Tennessee kindly supplied the analyzed mineral samples.

REFERENCES

- BERKELHAMER, L. H. (1945), An apparatus for differential thermal analysis: *Bureau of Mines R. I.* **3762**, 17 pages.
- GRIM, R. E., AND BRADLEY, W. F. (1940), Investigation of the effect of heat on the clay minerals illite and montmorillonite: *Jour. Am. Ceram. Soc.*, **23**, 242-248.
- GRIM, R. E., AND ROWLAND, R. A. (1942), Differential thermal analysis of clay minerals and other hydrous materials: *Am. Mineral.*, **27**, 746-761; 801-818.
- HENDRICKS, S. B., GOLDRICH, S. S., AND NELSON, R. A. (1946), On a portable differential thermal outfit: *Econ. Geol.*, **41**, 41.
- JOURDAIN, M. A. (1937), Studies on the constituents of refractory clays by means of thermal analysis: *Ceramique*, **40**, 135-141.
- KERR, PUAL F., AND KULP, J. L., (1948) Multiple differential thermal analysis: *Am. Mineral.*, **33**, 387-419.
- NORTON, J. H. (1939), Critical study of the differential thermal method for the identification of the clay minerals: *Jour. Am. Ceram. Soc.*, **22**, 54-63.
- NORTON, F. H. (1940), Analysis of high-alumina clays by the thermal method: *Jour. Am. Ceram. Soc.*, **23**, 281-282.
- ORCEL, J., AND CAILLÈRE, S. (1933), Differential thermal analysis of the montmorillonite clays (bentonite): *Compt. Rend.*, **197**, 174-177.
- ORCEL, J. (1935), Differential thermal analysis in the determination of clays, laterites, and bauxites: *Cong. Internat. Mines, Met., Geol. Appl.*, 7th sess., Paris, 359-373.
- SPEIL, SIDNEY (1945), Applications of thermal analysis to clays and aluminous minerals: *Bureau of Mines R. I.* **3764**, 36 pages.