

The author is grateful to the Institute of Geophysics, University of California at Los Angeles, and especially to Professor D. T. Griggs and Professor G. C. Kennedy, for the use of their laboratory facilities for these experiments during the summer of 1957, and for many stimulating discussions.

REFERENCES

- HALL, SIR JAMES (1812), Account of a series of experiments showing the effects of compression in modifying the action of heat: *Trans. Roy. Soc. Edinburgh*, 6, 71-184.
HEARD, H. (1957), unpublished experiment.
SMYTH, F. H. AND ADAMS, L. H. (1923), The system CaO-CO₂: *J. Am. Chem. Soc.*, 45, 1167-1184.

THE AMERICAN MINERALOGIST, VOL. 43, MAY-JUNE, 1958

A NEW LOW-TEMPERATURE, LIQUID HEATING STAGE*

WILLIAM W. VIRGIN, JR., AND CAMILLO J. MASSONI,
U. S. Geological Survey, Washington 25, D. C.

A new low-temperature, liquid heating stage for the study of liquid inclusions has been designed and constructed at the U. S. Geological Survey. The stage (Figs. 1 and 2) is mounted on the microscope and has an operating range of 30° to 300° C. Features of the heating stage are: (1) a totally immersed mercury thermometer, (2) a three-way adjustable crystal mount that will take a variety of attachments for holding crystals, (3) the accommodation of crystals as much as 3 inches in length, and (4) an easily controllable heating rate.

The basic construction of the heating stage is of a high-temperature resistant material composed of asbestos fibers, diatomaceous silica, and an inorganic binder. The material is light, mechanically strong, and easily fabricated. Aluminum is used as an inside shield and viewing-cell holder on the cover of the stage (Fig. 2A). Clamps for the cover and for securing the stage to the microscope are also made of aluminum. The crystal-mount assembly (B) is made of brass. The heating cell (C) is made from the bottom of a 600 ml. beaker cut to a height of 1½ inches. An 8-mm. glass tube, 15½ inches long, is fused to the side of the heating cell. This tube is just large enough to allow the passage of a 360° C. mercury thermometer (K) graduated in degree intervals. A stiff wire attached to the thermometer and extending through a cork in the end of the tube permits the thermometer to be moved in and out of the heating cell.

The glass viewing cell (D), 45 mm. outside diameter by 35 mm. deep, was specially made with an optical-glass bottom for maximum visibility. A 50-ml. beaker cut to a height of 35 mm. and ground and polished on

* Publication authorized by the Director, U. S. Geological Survey.

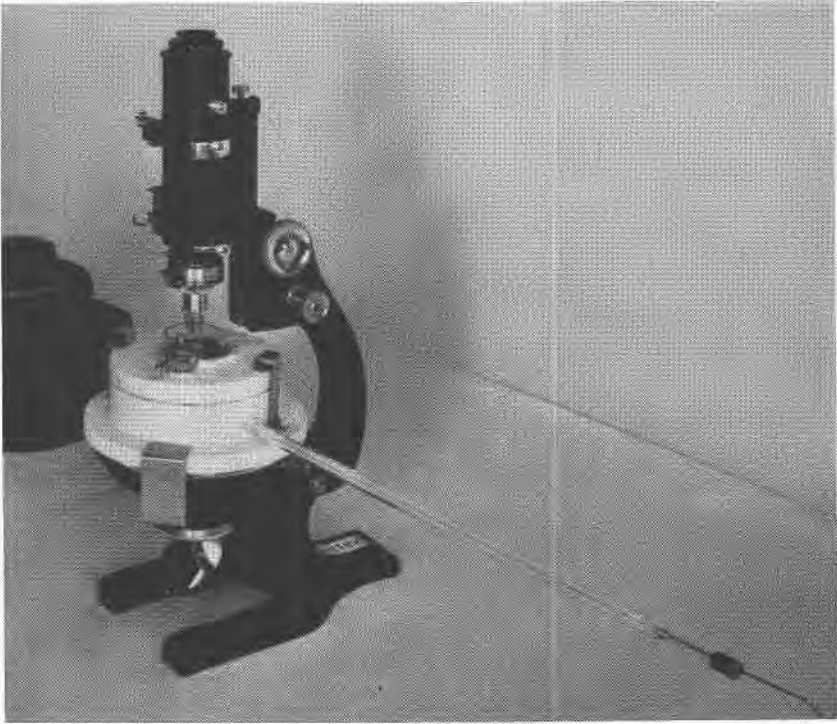

FIG. 1. Liquid heating stage mounted for use.

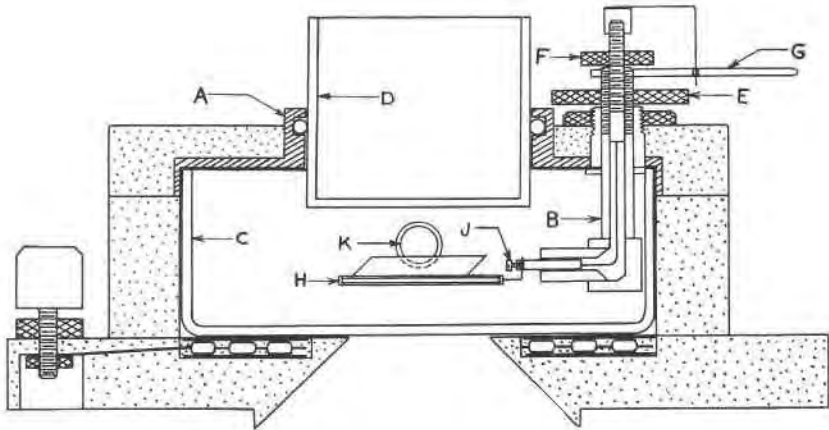

FIG. 2. Cross-section of liquid heating stage: (A) viewing cell holder; (B) crystal-mount assembly; (C) heating cell; (D) viewing cell; (E) and (F) adjustable nuts for vertical and north-south movements; (G) handle for east-west movement; (H) crystal holder; (I) small screw; (K) thermometer.

both inside and outside of the bottom surfaces to lessen effects of distortion can also be used satisfactorily but does not give the clear, undistorted image obtained with the special cell. The viewing cell is held in place by a rubber ring fitted in the opening of the aluminum part of the cover. Although the viewing cell is held tightly, a little silicone grease on the ring allows vertical adjustment.

The crystal mount is constructed to permit vertical, east-west, and north-south movements. The vertical and north-south movements are controlled by adjustable nuts (E and F) on the crystal positioning mechanism outside the cover, and the east-west movement, in the form of an arc, is controlled by a handle (G) securely attached to the same mechanism. The crystal holder (H) consists of a circular piece of glass held by a brass ring with a small piece of stiff wire attached to the rim of the ring. This unit is fastened to the crystal mount by means of a small screw (J). The size or type of crystal holder can be made to suit the needs of the operator.

The heating medium, essentially tetrachlorobiphenyl, is a colorless liquid used commercially as a heat-transfer medium. It is quite stable, remains essentially colorless during long intervals of heating and has a distillation range of 345° to 385° C. The heating cell holds approximately 125 ml. of this liquid when in use. Although the stage is essentially a closed system, some fumes do appear at temperatures above 200° C. The fumes are toxic and it is advisable to operate the stage under a ventilated hood when working in the range of 200° to 300° C.

The heating element consists of a coil of 2½ feet of no. 20 nichrome wire insulated with ceramic beads (Fig. 2). Two circular pieces of sheet mica with 1½-inch diameter holes, centrally located, are placed above and below the coil in the heating chamber to aid in even heat distribution to the heating cell. The coil is connected directly to a 7½-ampere, 110-volt variable transformer. The rate of temperature increase can be controlled quite easily, or the temperature can be held at any desired point over a period of time.

The accuracy of thermometer readings was checked by the use of melting point standards, organic and inorganic crystals enclosed in small glass tubes, at several points below 285° C. The standards were first checked on a Kofler micro-hot stage.¹ The melting points obtained with both stages are given in Table 1. The close agreement of the results indicates the accuracy to be expected with the liquid heating stage. The variation in temperature across the diameter of the heating cell is less than 1° C. at any temperature below 300° C.

¹ Cheronis, N. D., 1954, *Micro and semimicro methods*, Volume VI of *Technique of organic chemistry*, A. Weissberger, ed.: New York, Interscience Publishers, Inc., pp. 162-168.

TABLE 1. COMPARISON OF LIQUID HEATING STAGE WITH THE KOFLER MICRO-HOT STAGE

Melting point standard	Kofler micro-hot stage	Liquid heating stage
Vanillin	80.5°- 81° C.	80° - 81° C.
Benzoic acid	122 -123	121.5-122.5
Ammonium nitrate	168 -169.5	167 -169.5
Silver nitrate	209 -213	209 -211
Sodium chlorate	255 -258	254 -258
Anthraquinone	283 -286	282 -285

We wish to thank Joseph F. Abell and Irving Breger, of the U. S. Geological Survey, for their many helpful contributions toward the design and construction of this heating stage. This work is part of a program being conducted by the U. S. Geological Survey on behalf of the Division of Raw Materials of the U. S. Atomic Energy Commission.

ADDENDUM TO THE PEGMATITE PHOSPHATES

D. JEROME FISHER, *University of Chicago, Chicago 37, Illinois.*

Since the time of the deadline for copy for the paper "Pegmatite Phosphates and Their Problems" (*Am. Mineral.*, **43**, 181) it has been possible to secure samples of rare minerals not previously at hand. The powder diffraction patterns of these appear in Fig. 7. The accompanying table may be considered as an extension of Table 7 of the original paper; all these minerals are there listed in Table 8, except for the recently described hydrous Fe-Mn phosphate *strunzite*, known as fibrous emplacements in cavities from New Hampshire, Maine and Bavaria. Samples A, C-E, G and H are from Professor Frondel, K is from Professor Strunz, and B is from the American Museum of Natural History.

TABLE 7. PEGMATITE PHOSPHATE POWDER DIFFRACTION DATA

Strongest line	Second line	Third line	Name	Photograph	Locality	Crystal system	a/b
2.83	9.0 / 8	4.43/7	Phosphophyllite	7A	Hagendorf	M	2.065
2.91	2.18/7	2.97/6	Lacroixite	7B	Saxony	M?	—
3.01	2.81/8	3.49/7	Vashegyite	7C	Nevada	—	—
3.05	3.50/8	2.69/8	Xanthoxenite	7D	N. Hampshire	M?	—
3.10	4.37/8	2.90/7	Palermoite	7E	N. Hampshire	O	.730
3.45	7.3 / 8	2.89/8	Väyrynenite	7F	Finland	M?	—
4.18	3.39/8	3.23/7	Parsonsite	7G	N. Hampshire	M	—
7.84	3.95/7	5.82/6	Phosphuranylite	7H	Rumania	O	.910
9.02	5.32/7	3.23/4	Strunzite	7J	N. Hampshire	M	0.543
9.93	6.75/7	3.05/5	Stewartite	7K	Hagendorf	M	.171