

CALCIUM-BEARING MAGNESIUM-IRON OLIVINES

TH. G. SAHAMA AND KAI HYTÖNEN, *Institute of Geology,
University of Helsinki, Finland.*

ABSTRACT

Chemical and optical data are presented for ten calcium-bearing magnesium-iron olivines, five of which are previously unpublished. The d -spacings of the plane (130) have been measured for these olivines. Indexed powder patterns and calculated unit cell dimensions of the iron-poor monticellite from Dewey Mine and of a synthetic kirschsteinite are tabulated.

Excluding calcio-olivine and the manganoan olivines, the variation of the chemical composition in the olivine group is diagrammatically presented in Fig. 1. Optical and x-ray identification of olivines belonging to the monticellite-kirschsteinite series, of sub-calcium olivines and of slightly calcian olivines of the forsterite-fayalite series is discussed.

INTRODUCTION

If pure calcio-olivine and the manganoan olivines are excluded, the compositions of olivines may be summarized as in Fig. 1. In natural rocks forsterite and fayalite are known to form solid solutions with each other in all proportions. No evidence has ever been produced that would indicate any immiscibility gap in the sub-solidus range. Despite the common occurrence of olivines of the forsterite-fayalite series in rocks, analyzed olivines of this series never show appreciable contents of calcium. The figures for CaO are usually insignificant and only exceptionally reach 2 percent. From the Island of Fogo, Cap Verde Islands, an olivine with ca. 5% CaO has been reported in 1855 (Doelter, 1914, p. 299), but this information needs verification. Accordingly, the composition of the olivines belonging to the forsterite-fayalite series may be schematically represented by the small open circles on the bottom of Fig. 1.

On the other hand, the olivines of the natural monticellite-iron monticellite series mostly show a very slight deficiency in calcium. The ratio of magnesium to ferrous iron varies within relatively narrow limits. This range of variation that is schematically indicated by the small open circles near the left top of Fig. 1, has been recently expanded through the discovery of a calcium-bearing olivine from Mt. Shاهرu in the Nyiragongo area (Sahama and Hytönen, 1957). The composition of this olivine, No. 2 in Fig. 1, lies closer to the iron end member of the series for which the name kirschsteinite was proposed.

Of synthetic orthosilicates corresponding to the natural olivines of Fig. 1, the Mg_2SiO_4 - Fe_2SiO_4 series represents one of the most classical examples of unlimited solid solubility. An unbroken solid solution series has also been found between Fe_2SiO_4 and $CaFeSiO_4$ by Bowen, Schairer and Posnjak (1933). The phase diagram of this series contains a minimum melting point and no eutectic. Finally, between $CaMgSiO_4$ and $CaFeSiO_4$

a continuous solid solution series was shown to exist by Schairer and Osborn (1950). In the iron-free Mg_2SiO_4 - $CaMgSiO_4$ series, on the other hand, the conditions are different. As has been recently shown by Ricker and Osborn (1954), the solid solubility in this series is very limited. At $1100^\circ C.$, exsolution was observed in all mixtures except the 10% Mg_2SiO_4 and 10% $CaMgSiO_4$ compositions. At lower temperatures the solid solubility is apparently still more limited.

On the basis of the experience obtained from the above synthetic studies combined with observations on natural olivines, the compositions of calcium-magnesium-iron olivines in proper olivine-bearing rocks may

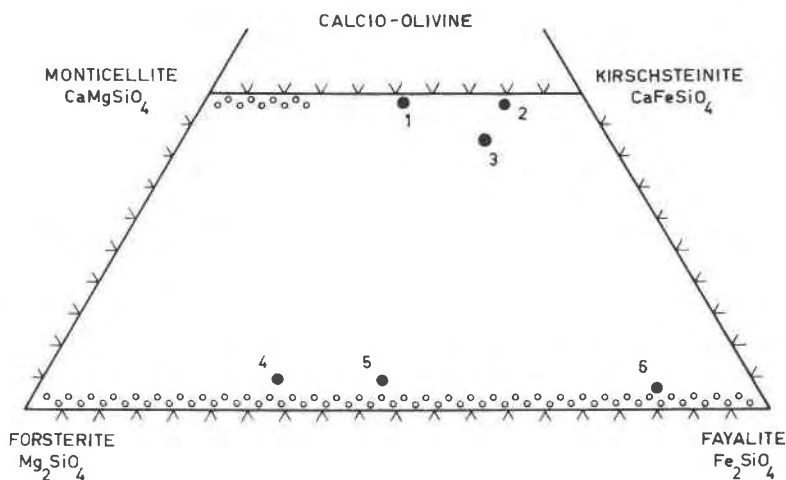

FIG. 1. The calcian-magnesian-ferroan olivines.

1. Ferroan monticellite. VM 394. Shaheru.
2. Magnesian kirschsteinite. S. 80. Shaheru.
3. Sub-calcium olivine. R.G. 22778. Nyiragongo.
4. Calcian hyalosiderite. S. 81. Shaheru.
5. Calcian hyalosiderite. Lunghezza.
6. Calcian ferrohortonolite. S. 90. Baruta.

be anticipated to cover the whole range from monticellite to kirschsteinite. In addition, in contrast to the magnesium end in the field Mg_2SiO_4 - $CaMgSiO_4$ - $CaFeSiO_4$ - Fe_2SiO_4 of Fig. 1, nothing is known at present that would make impossible the existence of olivines intermediate between the monticellite-kirschsteinite and the forsterite-fayalite series close to their iron ends. In analogy to the augitic clinopyroxenes, the olivines of such intermediate compositions may be called sub-calcium olivines. The fact that these hypothetical sub-calcium olivines and, with the exception of olivine No. 2 in Fig. 1, the iron-rich members of the monticellite-kirschsteinite series have not been recognized in nature,

might be caused by the great rarity of rock types in which those olivines may crystallize. Olivines of such extraordinary rocks have not been subjected to sufficiently detailed mineralogical study.

The authors of this paper were led to the above views on studying the mineralogy and petrology of the lavas of the Nyiragongo area in North Kivu, Belgian Congo. The rocks of this area are largely melilite-nephelinites with varying ratio of magnesium to iron. Such rocks seem to provide a chemical environment suitable for the formation of olivines of compositions indicated above. For that reason, some of the rock specimens available to the authors from that area were studied with respect to their olivines. The chemical, optical and physical data for these olivines and for samples from other sources are presented.

DESCRIPTION OF SAMPLES

Optical and physical data and calculated molecular compositions for the olivines used in this investigation are summarized in Table 1. The unpublished chemical analyses made of these olivines are collected in Table 2. The source of the specimens is listed below. All d -spacings of the plane (130) were measured by the authors according to the method that was used by Yoder and Sahama (1957) for the olivines of the forsterite-fayalite series.

Monticellite. Dewey Mine, San Bernardino Co., Calif. Batch of the original analyzed material chemically and optically investigated by Schaller (1935). Indexed powder pattern measured by the authors is given in Table 3.

Monticellite. Island of Skye, Broadford area, Scotland. Batch of the original analyzed material investigated by Tilley (1951).

Monticellite. Magnet Cove, Ark. Batch of the original analyzed material investigated by Neuvonen (1952).

Ferroan monticellite. Specimen VM. 394. Eastern wall of the Shahu crater, Nyiragongo area, Belgian Congo. Previously not published. The rock represents a fine-grained compact melilite-nephelinite lava with very few small phenocrysts of melilite, partly altered in the margins, and a few small aggregates of nepheline. The mesostasis consists of beautifully euhedral nepheline prisms poikilitically enclosed in crystals of colorless clinopyroxene, ferroan monticellite and, more rarely, by pale biotite. Magnetite, perovskite, apatite and small amounts of götzenite. A few patches of sodalite ($a_0 = 8.93 \text{ \AA}$). Composition of nepheline 34.7 mol. % Ks. The powder pattern of the separated nepheline fraction indicates presence of kalsilite of composition 98.6 mol. % Ks.

Magnesian kirschsteinite. Specimen S. 80. Northeastern wall of the Shahu crater, Nyiragongo area, Belgian Congo. Original material in-

TABLE 1. OPTICAL AND PHYSICAL DATA AND CALCULATED MOLECULAR COMPOSITIONS OF SOME CALCIAN MAGNESIUM-IRON OLIVINES

| | Monti-cellite | Monti-cellite | Monti-cellite | Ferroan monti-cellite | Magnesian kirschsteinite | Sub-calcium olivine | Synthetic kirschsteinite | Calcian hyalo-siderite | Calcian hyalo-siderite | Calcian ferro-horn-tonolite |
|----------------------------------|--------------------|--------------------------------|-------------------|--------------------------|--------------------------|-----------------------------|--------------------------|--------------------------|------------------------|-----------------------------|
| | Dewey Mine, Calif. | Skye, Broadford area, Scotland | Magnet Cove, Ark. | Shaheru, Nyiragongo area | Shaheru, Nyiragongo area | Nyiragongo, Nyiragongo area | — | Shaheru, Nyiragongo area | Luanghezha, Rome | Baruta, Nyiragongo area |
| | — | — | — | VM. 394 | S. 80 | R. G. 22778 | — | S. 81 | — | S. 90 |
| α | 1.641 | 1.645 | 1.651 | 1.674 | 1.689 | 1.693 | 1.696 | 1.687 | 1.728 | 1.792 |
| β | 1.649 | 1.654 | 1.657 | 1.694 | 1.720 | 1.728 | 1.734 | 1.707 | 1.757 | 1.827 |
| γ | 1.655 | 1.660 | 1.664 | 1.706 | 1.728 | 1.735 | 1.743 | 1.724 | 1.772 | 1.844 |
| 2V α | 80° ± | 80° | 72° | 65° | 51° | 61° | 50° ± 2° | 89° | n.d. | 55° |
| Sp. gr. | n.d. | 3.09 | 3.269 | 3.313 | 3.434 | n.d. | n.d. | 3.552 | n.d. | 4.019 |
| d ₁₀₀ | 2.9347 | 2.9392 | 2.9372 | 2.9415 | 2.9489 | 2.9379 | 2.9573 | 2.7927 | 2.8056 | 2.8306 |
| Fe ₂ SiO ₄ | 1.6 | 5.8 | 7.2 | 25.6 | 38.4 | 38.9 | 50 | 30.2 | 44.2 | 79.6 |
| Mn ₂ SiO ₄ | — | — | 1.3 | 1.3 | 2.1 | 1.9 | — | 1.2 | 1.7 | 3.8 |
| Mg ₂ SiO ₄ | 50.3 | 43.9 | 42.5 | 24.6 | 11.3 | 16.6 | — | 63.7 | 49.5 | 13.2 |
| Cu ₂ SiO ₄ | 48.1 | 50.3 | 49.0 | 48.5 | 48.2 | 42.6 | 50 | 4.9 | 4.6 | 3.4 |

TABLE 2. NEW CHEMICAL ANALYSES OF CALCIUM-BEARING
MAGNESIUM-IRON OLIVINES

| | Ferroan monticellite | Sub-calcium olivine | Calcian hyalosiderite | Calcian hyalosiderite | Calcian ferrohortonolite |
|--------------------------------|--------------------------------|-----------------------------------|--------------------------------|--------------------------|-------------------------------|
| | Shaheru, Nyiragongo area | Nyiragongo, Nyiragongo area | Shaheru, Nyiragongo area | Lunghezza, Rome | Baruta, Nyiragongo area |
| | VM. 394 | R.G. 22778 | S. 81 | — | S. 90 |
| SiO ₂ | 33.57 | 31.93 | 36.64 | 35.12 | 31.58 |
| TiO ₂ | 0.05 | 0.28 | 0.25 | 0.16 | 0.28 |
| Al ₂ O ₃ | 1.95 | 0.71 | 0.19 | 0.44 | 0.66 |
| Fe ₂ O ₃ | 1.40 | 1.87 | 3.02 | 1.65 | 3.26 |
| FeO | 19.34 | 28.94 | 23.66 | 34.53 | 52.97 |
| MnO | 1.06 | 1.50 | 1.01 | 1.34 | 2.64 |
| MgO | 11.07 | 7.33 | 31.26 | 22.64 | 5.22 |
| CaO | 30.40 | 26.15 | 3.37 | 2.95 | 1.84 |
| Na ₂ O | 0.60 | 0.38 | 0.18 | 0.26 | 0.54 |
| K ₂ O | 0.39 | 0.32 | 0.22 | 0.25 | 0.53 |
| H ₂ O+ | 0.13 | 0.46 | 0.23 | 0.56 | 0.38 |
| H ₂ O- | 0.05 | 0.03 | 0.06 | 0.10 | 0.10 |
| Total | 100.01 | 99.90 | 100.09 | 100.00 | 100.00 |

vestigated by Sahama and Hytönen (1957). Petrographic description of the rock has been given by Meyer and Sahama (1958).

Sub-calcium olivine. Specimen R. G. 22778. Top of Mt. Nyiragongo, Belgian Congo. Previously not published. Petrographic description of the rock has been given by Meyer and Sahama (1958). The rock is sprinkled with vesicles up to 2–3 mm. or sometimes even more in diameter. The vesicles are partly or wholly filled with well-developed crystals of green clinopyroxene, leucite, nepheline, reddish melilite, magnetite and drop-like nodules of pyrrhotite. In addition, these vesicles often contain yellowish or slightly greenish crystals of olivine that may reach the size of 1 mm. and sometimes show good crystal form of a shape indicated in Fig. 2. To separate the olivine for chemical analysis, the rock was crushed with a jaw crusher, not ground. The olivine crystals, thus liberated from the matrix, were collected with heavy liquids, then ground and subjected to a final heavy liquid separation. The deficiency in calcium in relation to the sum of iron, manganese and magnesium is considerably more pronounced than in the olivines of the monticellite-kirschsteinite series of which chemical composition is known. No sign of joint occurrence of two separate olivine phases, calcium-free and calcium-bearing, was detected in the analyzed material by powder pattern

TABLE 3. POWDER PATTERN OF MONTICELLITE FROM DEWEY MINE, SAN BERNARDINO CO., CALIF. FILTERED COBALT RADIATION WITH SILICON STANDARD
Indexing based on $a_0=4.827 \text{ \AA}$, $b_0=11.084 \text{ \AA}$, $c_0=6.376 \text{ \AA}$

| hkl | I | $2\theta_{\text{obs.}}$ | $d_{\text{obs.}}$ | $Q_{\text{obs.}}$ | $Q_{\text{calc.}}$ |
|-------|-----|-------------------------|-------------------|-------------------|--------------------|
| 020 | 15 | 18.525 | 5.557 | 0.03238 | 0.03252 |
| 021 | 35 | 24.685 | 4.185 | 0.05709 | 0.05711 |
| 101 | 10 | 26.905 | 3.845 | 0.06764 | 0.06750 |
| 111 | 40 | 28.475 | 3.637 | 0.07559 | 0.07563 |
| 002 | 15 | 32.59 | 3.188 | 0.09839 | 0.09836 |
| 130 | 35 | 35.49 | 2.9347 | 0.11611 | 0.11608 |
| 131 | 100 | 39.205 | 2.6661 | 0.14068 | 0.14067 |
| 112 | 40 | 40.48 | 2.5855 | 0.14959 | 0.14940 |
| 041 | 30 | 41.18 | 2.5434 | 0.15458 | 0.15467 |
| *140 | 25 | 43.735 | 2.4014 | 0.17340 | 0.17299 |
| *122 | | | | | 0.17379 |
| 210 | 7 | 44.65 | 2.3547 | 0.18035 | 0.17977 |
| 211 | 5 | 47.775 | 2.2088 | 0.20496 | 0.20436 |
| *113 | 15 | 55.66 | 1.9159 | 0.27242 | 0.27235 |
| 222 | 30 | 58.96 | 1.8175 | 0.30272 | 0.30252 |
| 061 | 10 | 60.46 | 1.7766 | 0.31682 | 0.31727 |
| 241 | 7 | 61.455 | 1.7505 | 0.32634 | 0.32631 |
| 133 | 15 | 62.655 | 1.7203 | 0.33790 | 0.33739 |
| 152 | 5 | 63.34 | 1.7036 | 0.34456 | 0.34452 |
| 043 | 5 | 64.04 | 1.6870 | 0.35137 | 0.35139 |
| *062 | 15 | 67.99 | 1.5997 | 0.39077 | 0.39104 |

* Broad line.

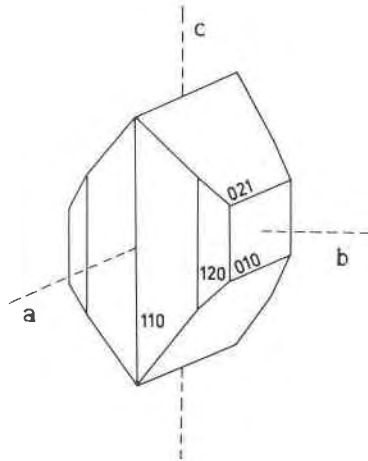

FIG. 2. The shape of the sub-calcium olivine crystals from Mt. Nyiragongo. Specimen R.G. 22778.

TABLE 4. POWDER PATTERN OF SYNTHETIC KIRSCHSTEINITE. FILTERED COBALT RADIATION WITH SILICON STANDARD

Indexing based on $a_0=4.886\text{\AA}$, $b_0=11.146\text{\AA}$, $c_0=6.434\text{\AA}$

| <i>hkl</i> | <i>I</i> | $2\theta_{\text{obs}}$ | d_{obs} | C_{obs} | Q_{calc} |
|------------|----------|------------------------|------------------|------------------|-------------------|
| 020 | 50 | 18.445 | 5.581 | 0.03210 | 0.03216 |
| 021 | 35 | 24.48 | 4.219 | 0.05617 | 0.05631 |
| 101 | 7 | 26.59 | 3.895 | 0.06591 | 0.06603 |
| 111 | 60 | 28.20 | 3.672 | 0.07416 | 0.07407 |
| 130 | 100 | 35.21 | 2.9573 | 0.11434 | 0.11424 |
| 040 | 30 | 37.43 | 2.7877 | 0.12867 | 0.12864 |
| 131 | 90 | 38.885 | 2.6872 | 0.13848 | 0.13839 |
| 112 | 95 | 40.05 | 2.6121 | 0.14656 | 0.14652 |
| 041 | 20 | 40.91 | 2.5594 | 0.15265 | 0.15279 |
| * { 140 | 35 | 43.36 | 2.4212 | 0.17058 | { 0.17052 |
| * { 122 | | | | | { 0.17064 |
| 132 | 10 | 48.545 | 2.1759 | 0.21121 | 0.21084 |
| * 240 | 60 | 58.34 | 1.8351 | 0.29694 | 0.29616 |
| 062 | 35 | 67.51 | 1.6098 | 0.38588 | 0.38604 |

* Broad line.

or under the microscope. Accordingly, the mineral is to be regarded a sub-calcium olivine intermediate between the monticellite-kirschsteinite and the forsterite-fayalite series. The optical orientation is the same as for the magnesian kirschsteinite from Shaheru.

Synthetic kirschsteinite. Optical data from Schaller (1935) and *x*-ray data on material obtained from Professor C. E. Tilley. The indexed powder pattern measured by the authors is summarized in Table 4.

Calcian hyalosiderite. Specimen S. 81. Southern wall of the Shaheru crater, Nyiragongo area, Belgian Congo. Previously not published. A brief description of the rock has been given by Meyer and Sahama (1958).

Calcian hyalosiderite. Lunghezza near Rome, Italy. Previously not published. The olivine occurs as well-developed crystals up to $\frac{1}{2}$ mm. in length together with nepheline, leucite, melilite and green clinopyroxene in cavities of a melilite-nepheline-leucite lava.

Calcian ferrohortonolite. Specimen S. 90. Southern upper part of Baruta, Nyiragongo area, Belgian Congo. Previously not published. A brief description of the rock has been given by Meyer and Sahama (1958).

The analyzed materials for three of the olivines (Shaheru VM. 394; Lunghezza; Baruta S. 90) were slightly contaminated by clinopyroxene. The analyses of these olivines were made by dissolving the materials in hot diluted hydrochloric acid and filtering off the remaining clinopyroxene. The clinopyroxene residue was separately tested by partial analysis to be free from gelatinous silica. Accordingly, the results of the

analyses that have been reduced to one hundred percent give the compositions of the olivines free from the clinopyroxene contamination.

MONTICELLITE-KIRSCHSTEINITE SERIES

Iron-rich olivines of the monticellite-kirschsteinite series have so far been found only in the melilite-nephelinite lavas of the Nyiragongo area. Accordingly, with the exception of the magnesian end of the series, optical and physical data for natural olivines of this series are too scarce for constructing determinative charts with the same accuracy as for the olivines of the forsterite-fayalite series. For that reason, no attempt will be made in this paper to prepare such charts. For purpose of identification of the olivines of the monticellite-kirschsteinite series, however, some qualitative statements may be made.

The following review, taken for forsterite and fayalite from Poldervaart (1950) and for monticellite and kirschsteinite from Schaller (1935), summarizes the refractive indices of these olivine end members:

| | Forsterite | Fayalite | Monticellite | Kirschsteinite |
|----------|------------|----------|--------------|----------------|
| α | 1.636 | 1.823 | 1.639 | 1.696 |
| β | 1.651 | 1.863 | 1.646 | 1.734 |
| γ | 1.669 | 1.875 | 1.653 | 1.743 |

If these refractive indices are plotted against the molecular content of the iron component, it will be seen that an accurate determination of the refractive indices alone will serve for distinguishing between the monticellite-kirschsteinite and the forsterite-fayalite series only if the molecular content of the iron component exceeds ca. 40 per cent. If, in addition to the refractive indices, the optic axial angle and/or the specific gravity is known, the distinction between the two series becomes possible even in the magnesian end.

The distinction between the monticellite-kirschsteinite and the forsterite-fayalite series becomes, however, more convenient by powder patterns. The d -spacings for the plane (130) of the above natural olivine end members are summarized below. The values for forsterite and fayalite have been taken from Yoder and Sahama (1957) and those for monticellite and kirschsteinite were roughly extrapolated from the data of Table 1.

| | $d_{(130)}$ | | $d_{(130)}$ |
|------------|-------------|----------------|-----------------|
| Forsterite | 2.7659 Å | Monticellite | 2.934 ± 0.001 Å |
| Fayalite | 2.8328 Å | Kirschsteinite | 2.956 ± 0.003 Å |

By measuring the value for $d_{(130)}$, the distinction between the two series is unequivocal and, in addition, gives an idea of the ratio of magnesium to iron. Such a determination of the composition of olivine by powder pattern is relatively accurate for the forsterite-fayalite series and, at

present, only very rough for the monticellite-kirschsteinite series. No additional optical or other physical data are necessary.

The above statements for the identification of the olivines of the monticellite-kirschsteinite series are valid only if the atomic content of calcium closely equals that of the sum of magnesium and iron (plus the small amount of manganese that is usually present). For a sub-calcium olivine, like R.G. 22778 from Nyiragongo that shows a marked deficiency in calcium, both optical and *x*-ray method alone will yield erroneous values for the content of CaFeSiO_4 . The molecular content of the kirschsteinite component will be found too high if deduced from the refractive indices and too low if estimated on the basis of the value for $d_{(130)}$. If the two methods give results considerably differing from each other, then it may be deduced that the olivine does not belong to the monticellite-kirschsteinite series proper but represents a sub-calcium variety. Such a discrepancy between the optical and *x*-ray data is actually the case for the sub-calcium olivine from Nyiragongo that is included in Table 1. As a general recommendation it may be stated that, if chemical analysis of an iron-rich olivine supposed to belong to the monticellite-kirschsteinite series will not be undertaken, the result of the *x*-ray determination should be tested by determining the refractive indices.

CALCIAN OLIVINES OF THE FORSTERITE-FAYALITE SERIES

Tables 1 and 2 contain three olivines (Shaheru S. 81; Lunghezza; Baruta S. 90) that represent slightly calcian members of the forsterite-fayalite series. These three olivines occur in melilite-bearing lavas very rich in calcium. If the values for $d_{(130)}$ for these calcian olivines are plotted in the *x*-ray determinative curve that has been published by Yoder and Sahama (1957), the fictive points will be found clearly above the curve. The amount of calcium contained in these olivines is sufficient to make the *x*-ray method inapplicable. This conclusion is illustrated by the following data:

| Mg Mg+Fe(+Mn) | Calcian hyalosiderite | Calcian hyalosiderite | Calcian ferrohortonolite |
|---------------------|--------------------------|--------------------------|-----------------------------|
| According to | Shaheru S. 81 | Lunghezza | Baruta S. 90 |
| Chemical analysis | 67.0 mol. % | 51.9 mol. % | 13.7 mol. % |
| $d_{(130)}$ * | 60.0 | 37.5 | 3.3 |
| Refractive indices† | 73 | 50 | 17 |

* Calculated according to the equation given by Yoder and Sahama (1957).

† According to the chart published by Poldervaart (1950).

The molecular content of the forsterite component is found too low with the x -ray method and mostly too high by determining the refractive indices. If the optical and the x -ray method give results clearly differing from each other, then the olivine may be expected to contain more calcium than is generally the case with the olivines of the forsterite-fayalite series.

ACKNOWLEDGMENTS

The authors are greatly indebted to the following contributors of specimens: Dr. Waldemar T. Schaller, of the U. S. Geological Survey, Washington, D. C. (Dewey Mine); Professor C. E. Tilley, of the University of Cambridge, England (Skye, synthetic kirschsteinite); Dr. K. J. Neuvonen, of the Geological Survey of Finland, Helsinki (Magnet Cove); Mr. André Meyer, of the Geological Survey of Belgian Congo, Goma (Shaheru VM. 394); Dr. Lucien S. Cahen, of the Musée Royal du Congo Belge, Tervuren, Belgium (Nyriragongo R. G. 22778); Professors Ettore Onorato and Mario Fornaseri, of the University of Rome, Italy (Lunghezza). The chemical analyses of Table 2 have been made by Mr. Pentti Ojanperä, of the Geological Survey of Finland, for which deep gratitude is expressed. The expenses of the analyses were covered by funds obtained from the Government Scientific Council of Finland. The authors are grateful for this generosity.

REFERENCES

- BOWEN, N. L., SCHAIRER, J. F. AND POSNJAK, E. (1933), The system, $\text{Ca}_2\text{SiO}_4\text{-Fe}_2\text{SiO}_4$: *Am. Jour. Sci.*, **25**, 273.
- DOELTER, C. (1914), Handbuch der Mineralchemie, II Erste Hälfte, p. 299.
- MEYER, A. AND SAHAMA, TH. G. (1958), Study of the volcano Nyriragongo. A progress report: Institut des Parcs Nationaux du Congo Belge, Mission d'études vulcanologiques, fascicule 2.
- NEUVONEN, K. J. (1952), Heat of formation of monticellite and merwinite: *Am. Jour. Sci.*, Bowen volume, 373.
- POLDERVAART, ARIE (1950), Correlation of physical properties and chemical composition in the plagioclase, olivine, and orthopyroxene series: *Am. Mineral.*, **35**, 1067.
- RICKER, R. W. AND OSBORN, E. F. (1954), Additional phase equilibrium data for the system CaO-MgO-SiO_2 : *Jour. Am. Ceram. Soc.*, **37**, 133.
- SAHAMA, TH. G. AND HYTÖNEN, KAI (1957), Kirschsteinite, a natural analogue to synthetic iron monticellite, from the Belgian Congo: *Min. Mag.*, **31**, 698.
- SCHAIRER, J. F. AND OSBORN, E. F. (1950), The system CaO-MgO-FeO-SiO_2 : I. Preliminary data on the join $\text{CaSiO}_3\text{-MgO-FeO}$: *Jour. Am. Ceram. Soc.*, **33**, No. 5, 160.
- SCHALLER, WALDEMAR T. (1935), Monticellite from San Bernardino County, California, and the monticellite series: *Am. Mineral.*, **20**, 815.
- TILLEY, C. E. (1951), The zoned contact skarns of the Broadford area, Skye: a study of boron-fluorine metasomatism in dolomites: *Min. Mag.*, **29**, 621.
- YODER, H. S., JR. AND SAHAMA, TH. G. (1957), Olivine X -ray determinative curve: *Am. Mineral.*, **42**, 475.

Manuscript received January 15, 1958