

THE AMERICAN MINERALOGIST, VOL. 48, MARCH-APRIL, 1963

TWO DEVICES FOR RAPID MEASUREMENT AND
COMPARISON OF X-RAY POWDER PATTERNSSIGMUND CH. KORITNIG, *Mineralog. Institut, Univ.
Göttingen, Germany.*

Though counter methods are gradually replacing photographic registration, powder patterns on photographic films still retain their value for a variety of applications. Compared with the rapid and accurate registration of counter diffractometers, the measuring and comparing of films seem to involve a relatively large amount of labor. In order to reduce the toil and to obtain reliable data in a short time, the two following, simple devices have been designed and successfully employed over a period of many years.

MEASURING SLIDE RULE

The general design is given in Fig. 1. The measuring device is made of aluminum (or similar material). The bottom frame, holding a glass window, has the outer dimensions of $220 \times 42 \times 4$ mm (size of the window: 204×25 mm). A center line runs along the total length of the glass window and a cross mark divides the line into two parts of equal length. The top frame (outer dimensions: $220 \times 42 \times 7.5$ mm; inner dimensions: 200×20 mm) is hinged to the rear of the bottom frame. A groove (with retaining spring) in the upper part of the top frame holds a sliding bar engraved with a .5 mm-scale (with a standard diameter of 57.3 mm for powder cameras, 1 mm thus corresponds to $1^\circ \theta$). A second scale gives 2θ -values. The zero point is located at the center of either scale, thereby permitting left and right-hand readings. (A scale giving d-values directly was found to be less useful, as the accurate reading and interpolation on a logarithmic scale proved to be difficult.) The bottom edge of the top frame is engraved with a stationary .5 mm-scale, extending from left to right. A slider, similar to those found on mathematical slide rules, runs across both types of scales. The window of the slider has a glass cube—fitting the inner dimensions of the top frame—glued to its reverse side. The center of the slider's window is marked with a narrow, vertical line (verniers can be added, if desirable). Two small, sharp-pointed rivets on the inner side of the top frame,¹ about 100 mm apart, serve to hold films firmly in place during measurements. Two corresponding borings on the inside of the bottom frame house the rivets when the two frames of the measuring slide rule are closed.

¹ Not at the measuring device of Fig. 1.

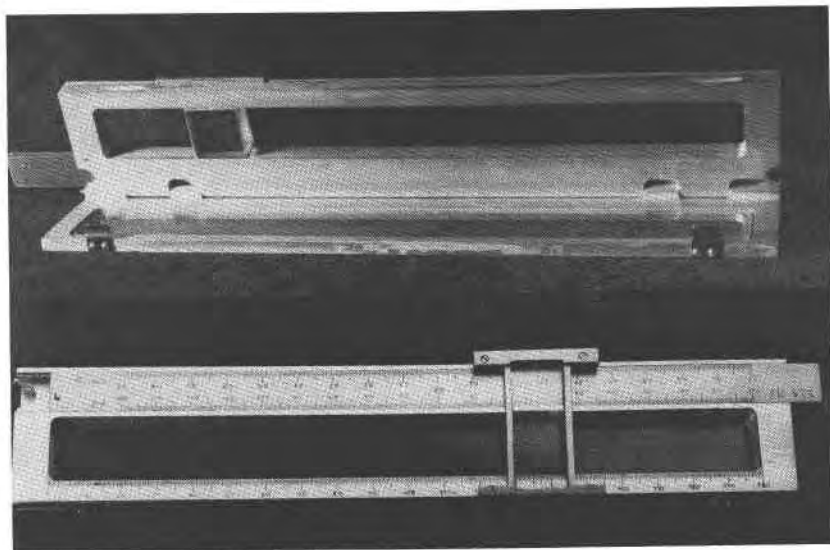

FIG. 1. Measuring slide rule. Above: opened; below: closed.

The measurement of films: The film is placed with its equator along the center line of the glass window in the bottom frame, and with its primary beam hole approximately at the cross mark. After this, the top frame is closed, whereby the pin-pointed rivets are pressed through the edge of the film, thus securing it without causing damage. With the aid of the slider, a characteristic pair of Debye-Scherrer-lines is measured, using the stationary scale at the bottom of the top frame. The vertical center line of the slider is shifted to the mean value of the previous two readings, *i.e.* the accurate center of the film. Next, the zero-point of the sliding bar should be moved to coincide with the center line of the slider. Corresponding pairs of lines on the right and left hand side of the film should now give identical readings on the scales of the sliding bar. For more accurate measurements, the arithmetic means of right and left hand measurements can easily be calculated. In complex patterns, corresponding lines on the two halves of the film can be located without difficulty. For better viewing, the slide rule should be placed on a light box. The observation of very weak lines is facilitated by holding the slide rule against the sky. The accuracy obtainable is comparable to measurements with other .5 mm-scales. The measurement of other types of films (*e.g.* Guinier, Straumanis films etc.) is easy and follows the same principle outlined above. By attaching the hinges to the narrow side of the two frames, the measuring slide rule can be moved across the total area of larger films (*e.g.* oscillation, rotation, Weissenberg films), however, this implies, that the rivets securing the film should be removed,

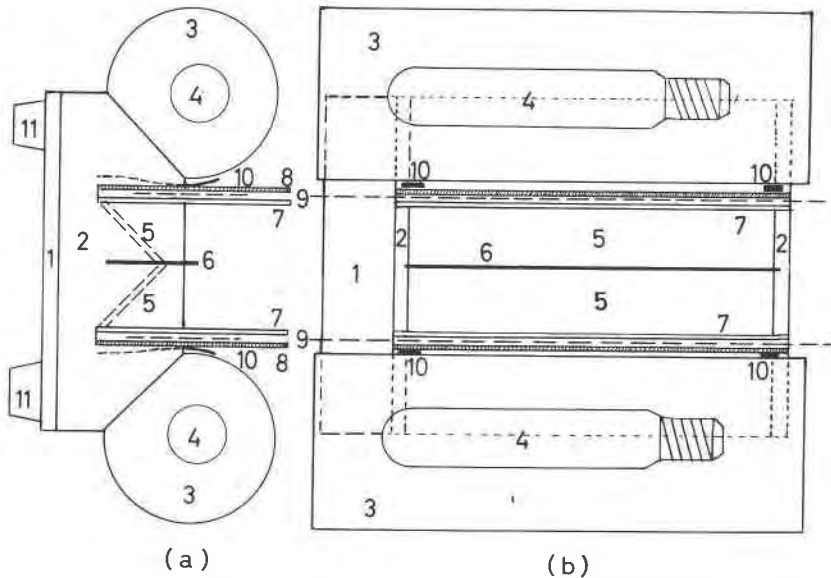

FIG. 2. Comparison viewer. (a) profile, (b) ground-plan, (1) base ($110 \times 152 \times 4.5$ mm), (2) side walls (thickness 4.5 mm), (3) lamp enclosure, (4) cylindrical light bulbs (25 watts each), (5) mirror (122×29 mm), (6) blackened partition wall ($122 \times 30 \times 4$ mm), (7) clear glass plates (122×62 mm), (8) opal glass plates (120×62 mm), (9) film, (10) springs to hold opal glass plate and film in place, (11) rubber discs.

COMPARISON VIEWER

This device is meant to facilitate the comparison of two *x*-ray powder patterns for identification purposes; for instance, minor shifts of lines in solid solution systems or changes in intensity or line width can thus easily be observed. The principle of the viewer is the simultaneous projection (by means of a mirror) of two powder films; *i.e.* the equators of the two films are being optically brought into contact. Constructional details are represented by Fig. 2. The viewer is made of aluminum (or light-metal alloys).

For comparative viewing, the equators of the films (9) are marked by pencil or needle and placed between the opal glass plate (8) and the clear glass plate (7). When viewing the films vertically, the equator of each film should coincide with the spur of the partition wall (6). Films taken with the same type of camera and submitted to identical treatment, should thus reveal even minute differences in their patterns, which otherwise might easily be attributed to inaccurate measurement.

For the English translation I wish to thank Dr. H.-G. Bachmann very much.