

## Diffusive and displacive transformation in plagioclase and ternary feldspar series<sup>1</sup>

HERBERT KROLL AND HANS-ULRICH BAMBAUER

*Institut für Mineralogie, Gievenbecker Weg 61  
D-4400 Münster, Federal Republic of Germany*

### Abstract

The temperature of the displacive triclinic/monoclinic transformation,  $T_{\text{displ}}$  of synthetic plagioclases and ternary feldspars was determined from high-temperature X-ray powder photographs.  $T_{\text{displ}}$  increases with increasing Ab + An content in ternary feldspars and with increasing An content in the plagioclase series such that plagioclase with more than  $\approx 15$  mol% An cannot become monoclinic before melting. The temperatures of the displacive and diffusive transformation of plagioclases coincide. K-exchange experiments are used to discuss the Al,Si topochemistry of the samples.

### Introduction

The first detailed and thorough account of the displacive transformation of plagioclases and ternary feldspars was made by Laves (1952) and MacKenzie (1952). They determined the triclinic/monoclinic transition temperatures from optical data or line splittings in X-ray powder diagrams. A study of the transformation requires that the samples under investigation be grown with monoclinic Al,Si distribution. Otherwise, a displacive transformation cannot occur, and the extrapolation of extinction angles or line splittings to zero results in a "simulated transformation". Kroll *et al.* (1980) and Kroll (in preparation) describe the characteristics that distinguish a "simulated transformation" from a true triclinic/monoclinic change. Their investigations on alkali feldspars are extended in this paper to plagioclases and ternary feldspars. The reader is referred to their papers for an explanation of nomenclature and the concept of treating the structural and metrical changes that accompany the displacive and diffusive processes.

### Experimental

#### *Ternary feldspars*

To investigate meaningfully the displacive transformation of feldspars the samples under consideration have to be topochemically monoclinic. Because the temperatures of the diffusive transformation are not known in the ternary feldspar field, it is impossible to know *a priori* the topochemistry of the samples which are to be hydrothermally synthesized from gels or glasses. Another problem in preparation is caused by the large unmixing gap.

Both difficulties can be overcome by the K-exchange method of Viswanathan (1971). Several samples of low plagioclases approximately in the range  $An_0$  to  $An_{50}$  were chosen from the Corlett and Eberhard (1967) collection and K-exchanged in molten KCl (850°C, 2-12h). They were then dry heated at 1100°C for 10 days. All samples between  $An_0$  and  $An_{\approx 33}$  attained monoclinic cell dimensions at room temperature. Obviously, the (K,Ca)-microclines into which the plagioclases were converted by the K-exchange had become topochemically monoclinic (K,Ca)-sanidines. Several of these (K,Ca)-sanidines were back-exchanged in molten NaCl (850°C, 2-12h) to give topochemically monoclinic plagioclases. Two samples were chosen to prepare ternary series from the end-members  $Ab_{83.5}An_{16.5}-Or_{83.5}An_{16.5}$  and  $Ab_{72.2}An_{27.8}-Or_{72.2}An_{27.8}$  by homogenizing at 1000°C

<sup>1</sup> Second part of a series on diffusive and displacive transformation of feldspars (Na,K,Ca)[(Al,Si)Si<sub>2</sub>O<sub>6</sub>] presented IN MEMORIAM FRITZ LAVES. The first part, "The high albite-monalbite and analbite-monalbite transitions," appeared in *The American Mineralogist*, 65 (1192-1211, 1980).

weighed mixtures that had been pressed into tablets (1 kbar). In this way it is possible to obtain topochemically monoclinic ternary feldspars which cannot be directly synthesized.

Lattice parameters for the heat-treated, K-exchanged equivalents, their Na-back-exchange products, and the  $An_{27.8}$  ternary series (Tables 1 and 2) were determined by the Guinier-Jagodzinski technique ( $CuK\alpha_1$  radiation). Further details on sample preparation and the procedure of determining lattice parameters are given by Kroll (1971) and Kroll *et al.* (1980).

### Plagioclases

Only Na-rich plagioclase can be prepared with a topochemically monoclinic Al,Si distribution. The following samples were synthesized:  $An_6$  and  $An_{12}$  by hydrothermal crystallization of gels at  $1040^\circ C$ ,  $P(H_2O) = 5$  bars for 15 days;  $An_{10}$  and  $An_{20}$  by dry crystallization of glasses at  $1055^\circ C$  and  $1090^\circ C$ , respectively, for 15 days. The preparation of the gels and glasses is described by Kroll *et al.* (1980).

Judging from the run duration and synthesis temperatures, the Al,Si distribution of the plagioclases attained equilibrium (also compare Eberhard, 1967).

### High temperature X-ray measurements

To follow the approximation to monoclinic cell dimensions with increasing temperature, the plagioclases and ternary feldspars were X-rayed at elevated temperatures. The splitting of the (111) line,  $\Delta 111 = 4\theta(111) - 4\theta(1\bar{1}1)$ , was measured and plotted as 1-

$\cos^2(\Delta 111)$  vs. temperature. The resultant straight line relationship can then be used to determine  $T_{displ}$  by extrapolation to  $1 - \cos^2(\Delta 111) = 0$  (Kroll *et al.*, 1980, Fig. 5).

### High temperature X-ray powder camera

A Guinier-Jagodzinski type camera that was designed by Kroll (1971) and modified by Schirmer (1976) was used to take the high temperature photographs in this study and that of Kroll *et al.* (1980). Its main features are illustrated in Figure 1. The X-ray beam ( $CuK\alpha_1$  radiation) penetrates the sample at an angle of 45 degrees. The sample holder is a Pt net of  $4 \times 12$  mm, sealed on a heat-resistant metal frame that is moved by  $\pm 5$  mm on the focusing circle. The furnace is a resistant-furnace, consisting of several bars of  $Al_2O_3$  ceramics around which a resistance wire is wound. The bars are placed around the sample holder and kept within a silica glass tube, whose surface is covered by Au foil to reflect the IR radiation. The entire furnace is held in a water-cooled metal case. The maximum temperature that can be reached is  $1100^\circ C$ . This construction prevents any contamination of the sample during heating.

The temperature is held constant to  $\pm 2.5^\circ C$  below about  $500^\circ C$  and  $\pm 0.5^\circ C$  above  $500^\circ C$  by a thyristor-controller that is connected to a Pt-PtRh (DIN) thermocouple placed near the resistance wire. The temperature of the sample is measured by a second thermocouple in the immediate vicinity (0.5 mm) of that part of the Pt net which is penetrated by the X-ray beam. The thermocouple was calibrated by visu-

Table 1. Lattice parameters of feldspars (a) that were prepared by K-exchange of low plagioclases in molten KCl and subsequent dry heat treatment at  $1100^\circ C$  for 10 to 20 days, and (2) that were then back-exchanged in molten NaCl.

Sample No.*	Or [Mol%]	Ab	An	Heat treatment T[ $^\circ C$ ] t[days]	a** [ $\text{\AA}$ ]	b [ $\text{\AA}$ ]	c [ $\text{\AA}$ ]	$\alpha$ [ $^\circ$ ]	$\beta$ [ $^\circ$ ]	$\gamma$ [ $^\circ$ ]	V [ $\text{\AA}^3$ ]	No. lines
1457(110)	95.9	0	4.1	1100 10	8.5704(6)	13.0309(6)	7.1768(5)	90	115.978(4)	90	720.5(1)	40
1455(84)	83.5	0	16.5	1100 10	8.4826(7)	13.0139(8)	7.1649(6)	90	115.968(4)	90	711.1(1)	37
4173(84)	0	83.5	16.5	back-exchanged	8.1608(8)	12.8697(8)	7.1099(6)	93.551(6)	116.325(5)	90.264(5)	667.6(1)	47
1454(166)	78.5	0	81.5	1100 10	8.4583(7)	13.0098(9)	7.1631(5)	90	115.962(5)	90	708.7(1)	27
1454(170)	74.7	0	25.3	1100 10	8.4300(8)	13.0035(8)	7.1554(5)	90	115.962(5)	90	705.2(1)	21
4170(170)	0	74.7	25.3	back-exchanged	8.1639(6)	12.8742(6)	7.1087(6)	93.477(5)	116.306(4)	90.349(4)	668.1(1)	56
1454(193)	74.4	0	25.6	1100 10	8.4286(8)	13.0010(7)	7.1565(4)	90	115.986(4)	90	704.9(1)	22
1480(193)	0	74.4	25.6	back-exchanged	8.1550(12)	12.8743(13)	7.1061(9)	93.477(10)	116.275(8)	90.404(7)	667.3(2)	34
1455(31)	72.2	0	27.8	1100 10	8.4141(5)	12.9980(5)	7.1535(3)	90	115.984(3)	90	703.3(1)	41
1479(31)	0	72.2	27.8	back-exchanged	8.1627(7)	12.8766(9)	7.1077(5)	93.508(6)	116.252(5)	90.409(5)	668.3(1)	36
1455(101)	72.0	0	28.0	1100 10	8.4177(10)	12.9973(9)	7.1533(8)	90	115.941(7)	90	703.8(2)	22
1552(136)	64.7	0	35.3	1100 20	8.3999(17)	12.9780(13)	7.1496(12)	90.715(12)	116.100(15)	90.075(13)	699.9(3)	32
4431(91)	52.2	0	47.8	1100 20	8.3375(20)	12.9516(17)	7.1292(18)	92.042(14)	116.068(16)	90.397(16)	690.7(4)	31

\* Bracketed numbers correspond to the sample numbers of Corlett and Eberhard (1967).

\*\* Standard errors are given in parentheses and refer to the last decimal place(s).

Table 2. Lattice parameters of a series of ternary feldspars with a topochemically monoclinic Al,Si distribution. They were prepared from samples (31) listed in Table 1 by dry homogenization at 1000°C of weighed mixtures.

Sample No.*	Or [mol%]	Ab	An	Homogenization T[°C]	t[hours]	a** [Å]	b [Å]	c [Å]	$\alpha$ [°]	$\beta$ [°]	$\gamma$ [°]	V [Å <sup>3</sup> ]	No. lines
1455(31)	72.2	0	27.8			8.4177(10)	12.9973( 9)	7.1533( 8)	90	115.941( 7)	90	703.8(2)	22
1529a	65	7.2	27.8	1000	26	8.3882( 9)	12.9933( 7)	7.1502( 5)	90	116.007( 5)	90	700.4(1)	27
1529b	55	17.2	27.8	1000	26	8.3641(13)	12.9774(15)	7.1460(12)	90.718(13)	116.102(12)	90.159(16)	696.5(3)	19
1523	45	27.2	27.8	1000	26	8.3158(10)	12.9630( 8)	7.1425( 6)	91.405( 8)	116.137( 6)	90.235( 7)	690.9(2)	31
1529c	35	37.2	27.8	1000	26	8.2774( 8)	12.9404( 9)	7.1350( 7)	91.991( 7)	116.172( 6)	90.309( 6)	685.3(1)	29
1533	25	47.2	27.8	1000	168	8.2461(15)	12.9258(13)	7.1280(11)	92.456( 9)	116.212( 9)	90.345( 8)	680.7(2)	26
1526	15	57.2	27.8	1000	14	8.2223( 9)	12.9136( 8)	7.1217( 8)	92.786( 6)	116.242( 7)	90.385( 8)	677.1(2)	31
1479(31)	0	72.2	27.8			8.1627( 7)	12.8766( 9)	7.1077( 5)	93.508( 6)	116.252( 5)	90.409( 5)	668.3(1)	36

\* Bracketed numbers correspond to the sample numbers of Corlett and Eberhard (1967).

\*\* Standard errors are given in parentheses and refer to the last decimal place(s).

ally observing the melting of several different substances ranging between 212°C and 1063°C (AgNO<sub>3</sub>, K<sub>2</sub>Cr<sub>2</sub>O<sub>7</sub>, Ba(NO<sub>3</sub>)<sub>2</sub>, NaCl, Ag, Au). They were placed on the sample holder itself or used in place of it (Ag,Au). We estimate the accuracy of the temperature measurement to  $\pm 5^\circ\text{C}$ .

## Results

### Topochemistry of plagioclases and their K-exchange products

The low plagioclases which were K-exchanged and then heated at 1100°C acquired monoclinic topochemistry and monoclinic cell dimensions when their An content was less than about 33 mol%. Samples with more than 33 mol% An, specifically Or<sub>64.7</sub>An<sub>35.3</sub> and Or<sub>52.2</sub>An<sub>47.8</sub>, retained triclinic cell dimensions, even after prolonged heating, as is seen from Figure 2a. It is possible, however, that these samples ac-

quired monoclinic topochemistry at 1100°C, but displacively inverted to triclinic symmetry on cooling. Their  $\gamma$  angles are definitely larger than those of synthetic high-temperature plagioclases, which were K-exchanged by Kroll and Müller, 1980 (Figure 2a). This indicates that the two samples in question are considerably more disordered than high-temperature plagioclases with the same An content, but without further experiments it is not possible to decide whether they are truly topochemically monoclinic. For monoclinic topochemistry the room temperature monoclinic/triclinic inversion in this K-exchanged series would correspond to that in the analbite-sandine series.

The  $\alpha$  and  $\gamma$  curves of the K-exchanged synthetic high-temperature plagioclases separate at An<sub>15-20</sub>. The An<sub>20</sub> lattice parameters could not be evaluated with certainty because the powder diagram shows considerable peak broadening, which indicates triclinic geometry. We conclude that high-temperature plagioclases are topochemically monoclinic in the compositional range An<sub>0</sub> to An<sub>15-20</sub>, but are triclinic when the An content is greater than 15-20 mol%. This is confirmed by a structure refinement of an An<sub>27.8</sub> high-temperature plagioclase that was prepared by dry heating from a low plagioclase. It was found to be topochemically triclinic (Kroll, 1978), and accordingly, its K-exchange equivalent is geometrically triclinic (marked by crosses in Fig. 2a). By contrast, An<sub>27.8</sub>, which was K-exchanged in the low structural state and subsequently heat-treated, is geometrically monoclinic, thus demonstrating its monoclinic topochemistry.

The structural differences between high-temperature plagioclases and Na-back-exchanged (K,Ca)-sanidines are further illustrated by comparison of their lattice angle  $\gamma$  (Fig. 2b). The  $\gamma$  values of the Na-

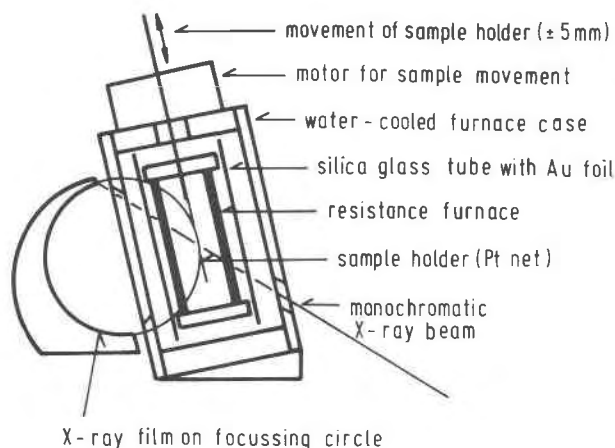

Fig. 1. Schematic drawing of the high-temperature X-ray camera used in this work and that of Kroll *et al.* (1980).

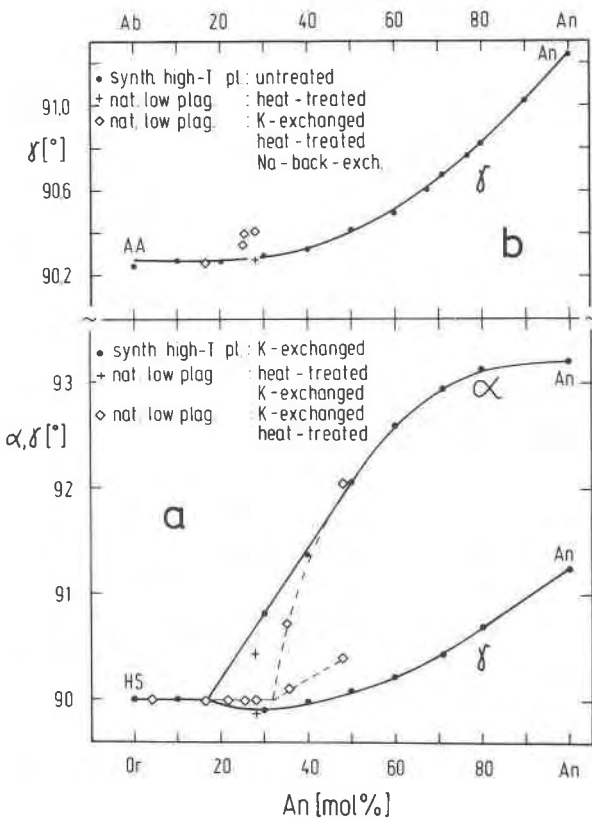

Fig. 2. (a) Variation with composition of  $\alpha$  and  $\gamma$  angles of Kroll and Müller's (1980) K-exchanged equivalents of high-temperature plagioclases (dots) plus K-exchanged and subsequently heated low plagioclases (diamonds). (b) Variation with composition of the  $\gamma$  angles of Kroll and Müller's (1980) high-temperature plagioclases (dots) plus Na-back-exchanged (K,Ca)-sanidines (diamonds).

back-exchanged (K,Ca)-sanidines  $An_{25.3}$ ,  $An_{26.6}$  and  $An_{27.8}$  are larger than those of the high-temperature plagioclases. This confirms their larger degree of disorder, which is anticipated from Figure 2a where their K-equivalents are found to be monoclinic. In contrast, the K-exchanged high-temperature plagioclases are triclinic when their An-content exceeds 15–20 mol%. In Figure 2b, the  $An_{16.5}$  sample plots near the high curve because an original high-temperature plagioclase of  $An_{16.5}$  is close to monoclinic topochemistry and thus cannot be distinguished from a Na-back-exchanged (K,Ca)-sanidine.

The (K,Ca)-microclines disorder much faster than low plagioclases of the same composition when heated at the same temperature (e.g., 1100°C). This is probably due to the fact that the diffusive transformation of a (K,Ca)-feldspar occurs at a much lower temperature than that of a plagioclase. Compare  $T_{diff}$

$\approx 450^\circ\text{C}$  of K-feldspar with  $T_{diff} \approx 980^\circ\text{C}$  of Na-feldspar (Kroll *et al.*, 1980, Table 3).

*Displacive transformation of ternary feldspars*

Figure 3a, b demonstrates the linear dependence of  $1 - \cos^2(\Delta 111)$  on temperature within the two topochemically monoclinic ternary series  $Or_{10-50} Ab_{73.5-33.5} An_{16.5}$  and  $Or_{15-55} Ab_{57.2-17.2} An_{27.8}$ . The points of intersection on the abscissa correspond to the displacive transformation temperatures (compare Kroll *et al.*, 1980, Fig. 5). In Figure 4 these temperatures are plotted vs. the Or content within the two series (curves 2, 3). Curve 1 shows the variation of  $T_{displ}$  in alkali feldspars ( $An_0$ ) that equilibrated at 1000°C (Kroll *et al.*, 1980, Eq. 1, Fig. 8). By analogy to curve 1, a parabolic fit was chosen for curves 2 and 3. The ordinate intercept of these curves indicates the temperatures at which topochemically monoclinic plagioclases  $An_{16.5}$  and  $An_{27.8}$  would become metrically monoclinic if permitted by the solidus temperatures (compare Fig. 6).

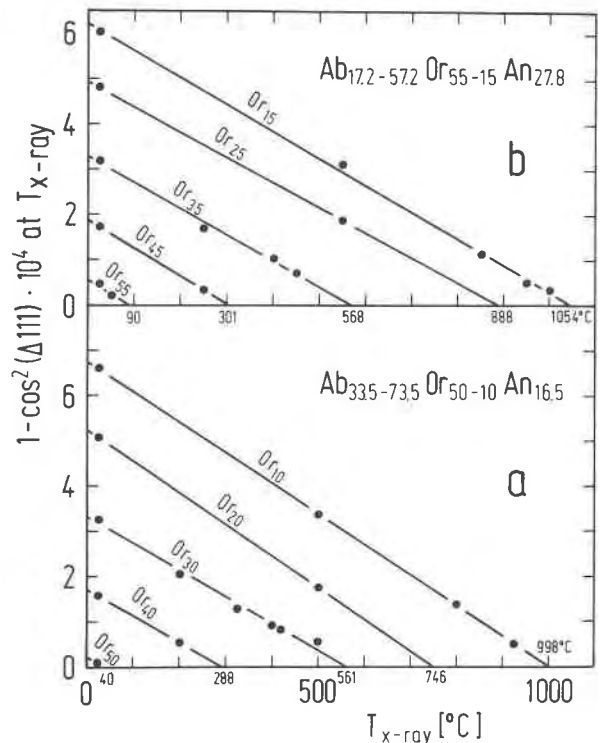

Fig. 3. Variation with temperature of the parameter  $1 - \cos^2(\Delta 111)$  within the topochemically monoclinic series (a)  $Or_{10-50} Ab_{73.5-33.5} An_{16.5}$  and (b)  $Or_{15-55} Ab_{57.2-17.2} An_{27.8}$ . The indicated temperatures of the displacive transformation,  $T_{displ}$ , were determined from linear least-squares fitting.  $\Delta 111 = 4\theta(111) - 4\theta(1\bar{1}1)$ ,  $CuK\alpha_1$ .

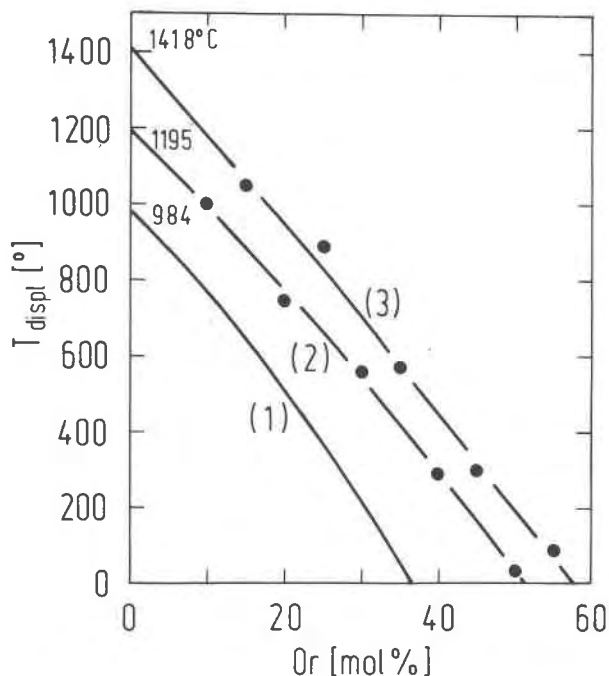

Fig. 4. Variation of  $T_{\text{displ}}$  with Or content in the ternary series of Figure 3. Curve 3:  $\text{Or}_{15-55}\text{Ab}_{57.2-17.2}\text{An}_{27.8}$ , curve 2:  $\text{Or}_{10-50}\text{Ab}_{73.5-33.5}\text{An}_{16.5}$ . Curve 1 is a plot of the variation of  $T_{\text{displ}}$  in the alkali feldspars calculated from Eq. 1 of Kroll *et al.* (1980) for an equilibration temperature of 1000°C.

#### Displacive transformation of plagioclases

The variation of  $1 - \cos^2(\Delta 111)$  with temperature is plotted in Figure 5 for the four plagioclases described in the experimental section. The topochemistry of these samples is not known *a priori*. A comparison of their temperatures of equilibration,  $T_{\text{equil}}$ , and the temperatures at which the straight lines intersect the abscissa, possibly representing  $T_{\text{displ}}$ , gives an indication.

As we discuss below, a temperature of intersection that is higher than  $T_{\text{equil}}$  does not correspond to  $T_{\text{displ}}$ . Otherwise, a topochemically monoclinic Al, Si distribution would have acquired equilibrium in a triclinic unit cell. This is, however, a contradiction in itself because symmetrically non-equivalent tetrahedral sites are energetically non-equivalent and thus cannot contain equal amounts of Al (Laves, 1960). Therefore, only the  $\text{An}_6$  sample where  $T_{\text{equil}}$  (1040°C)  $>$   $T_{\text{displ}}$  (1005°C) is topochemically monoclinic.

In Figure 6, the curve of the displacive transformation in plagioclases is drawn through the four data points available:  $\text{An}_0$  (984°C, Kroll *et al.*, 1980, Eq. 1),  $\text{An}_6$  (1005°C, Fig. 5),  $\text{An}_{16.5}$  (1195°C, Fig. 4) and  $\text{An}_{27.8}$  (1418°C, Fig. 4). This curve intersects the sol-

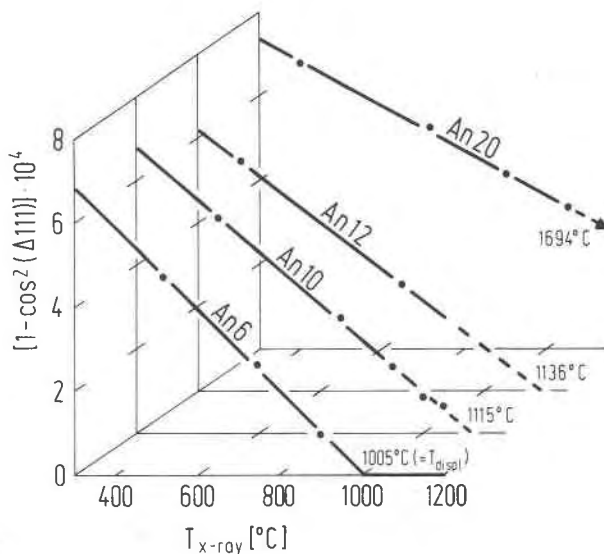

Fig. 5. Variation with temperature of the parameter  $1 - \cos^2(\Delta 111)$  for four plagioclases. The intersection with the abscissa corresponds to  $T_{\text{displ}}$  only in case of  $\text{An}_6$ .

idus curve at  $\approx \text{An}_{15}$ . Thus, there is only a small field where (Na, Ca)-monalbite exists. This result is in accordance with the results obtained from the K-exchange experiments (Fig. 2a). The pronounced increase of  $T_{\text{displ}}$  with An content is as expected: topochemically monoclinic anorthite is far from reaching monoclinic geometry even near its melting temperature (Czank, 1973).

Three other data points ( $\text{An}_{0.5,10}$ ) are plotted in Figure 6. They were obtained from the line splittings reported by MacKenzie (1952, Table 1, "Crystallized dry" and Table 3). They were linearized as  $1 - \cos^2(\Delta 111)$  and extrapolated to 939°C ( $\text{An}_0$ ), 967°C ( $\text{An}_5$ ), and 1023°C ( $\text{An}_{10}$ ). Although no crystallization temperatures were given for the "dry" samples, the extrapolation temperatures presumably correspond to the displacive transition. This would not be true for MacKenzie's  $\text{An}_{20}$  sample nor for any of his hydrothermally crystallized plagioclases. Possible reasons for the discrepancy between  $T_{\text{displ}}$  in MacKenzie's and our samples are discussed by Kroll (in preparation).

#### Diffusive transformation of plagioclases

The temperature of the diffusive transformation  $T_{\text{diff}}$  of Na-feldspar is  $\approx 980^\circ\text{C}$ . We expect it to increase with increasing An content based on the following reasoning. If we assume that  $T_{\text{diff}}$  is independent of An content, a sample of  $\text{An}_{30}$  prepared at 1000°C would be topochemically monoclinic and its

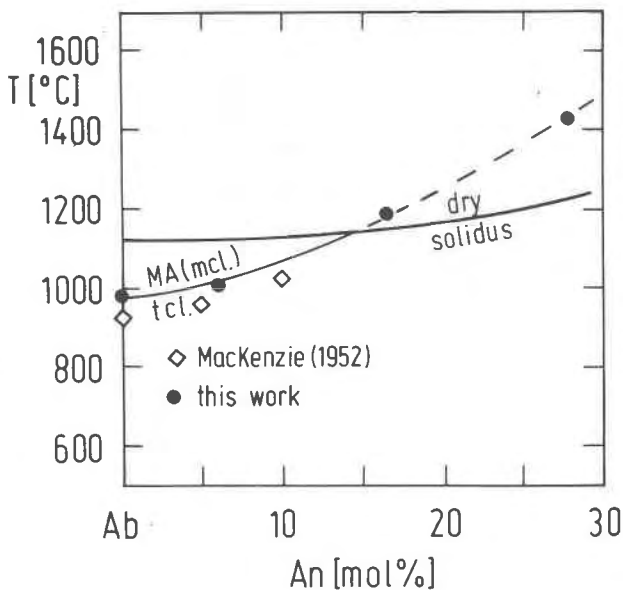

Fig. 6. Variation of  $T_{\text{displ}}$  and  $T_{\text{diff}}$  in sodic plagioclases. As discussed in the text,  $T_{\text{displ}}$  and  $T_{\text{diff}}$  are probably identical in the plagioclase series. For rapid cooling, therefore, the monoclinic/triclinic transition curve corresponds to the displacive transformation. For slow (equilibrium) cooling it corresponds to the diffusive transformation. The two data points that plot above the solidus curve were found by extrapolation of curves 2 and 3 in Figure 4.

displacive inversion would occur at about 1450°C (Fig. 6). This would mean that a topochemically monoclinic Al,Si distribution had equilibrated in a triclinic unit cell. We reject this possibility for reasons stated above. Consequently, the increase of  $T_{\text{displ}}$  with increasing An content causes an increase of  $T_{\text{diff}}$  to at least the same extent.

Furthermore, in alkali feldspars that are crystallized just above  $T_{\text{diff}}$  (Kroll *et al.*, 1980, Fig. 8)  $T_{\text{displ}}$  is lower than  $T_{\text{diff}}$ . This temperature difference decreases with decreasing Or content and equals zero at Ab<sub>100</sub>. It is highly unlikely that a further decrease of the relative size of the large cation (Na,Ca) with respect to the framework size (<Si,Al - O>) would cause  $T_{\text{displ}}$  again to fall below  $T_{\text{diff}}$  as in the alkali feldspars. We have thus excluded the possibility  $T_{\text{diff}} < T_{\text{displ}}$  as well as  $T_{\text{diff}} > T_{\text{displ}}$ . Therefore, we conclude that, as for Na-feldspar,  $T_{\text{displ}}$  equals  $T_{\text{diff}}$  in the plagioclases series (Fig. 6).

### Summary

The temperatures of the displacive transformation of alkali feldspars, plagioclases and ternary feldspars are summarized in Figure 7. This diagram replaces

Figure 2 of Kroll and Bambaer (1971), which was redrawn by Smith (1974, I, Fig. 7-60). Contours are drawn for 25°C, 500°C, and 1000°C. If the samples Or<sub>64.7</sub>An<sub>35.3</sub> and Or<sub>52.2</sub>An<sub>47.8</sub> are in fact topochemically monoclinic, the contours continue along the dashed curves to the Or-An side.

Transition temperatures as given by Laves (1952) and MacKenzie (1952) for some natural anorthoclases were added. Lacking suitable data, we were not able to redetermine these temperatures, and therefore they are not directly comparable to our data. However, for one synthetic sample, Or<sub>20</sub>Ab<sub>70</sub>An<sub>10</sub> (MacKenzie, 1952, Table 1), which most probably is topochemically monoclinic,  $T_{\text{displ}}$  was redetermined and is in excellent agreement with the contours.

As noted by Smith (1974, I, p. 353), the temperatures for the natural specimens are low compared to the synthetic samples (0°C to 250°C). This may be due to some replacement of (Na,K,Ca) by larger mono- and divalent cations (Rb,Sr,Ba).

In addition, Kroll *et al.* (1980) observe from their synthetic alkali feldspars that a decrease of the equil-

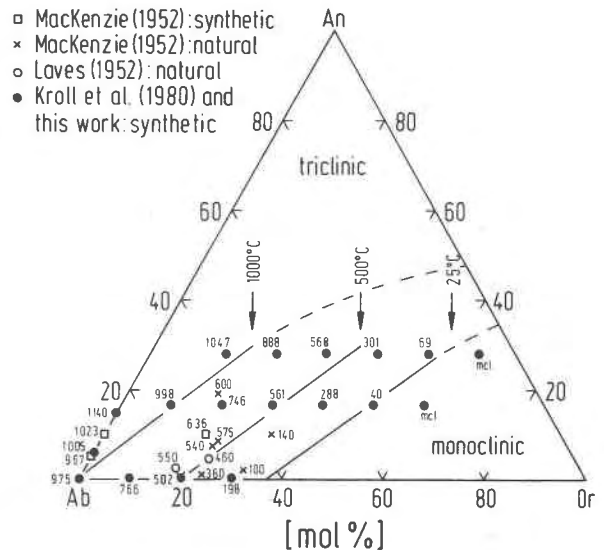

Fig. 7. Variation of  $T_{\text{displ}}$  [°C] in the ternary system Or-Ab-An.  $T_{\text{displ}}$  is indicated beside the data points. Contours drawn for 25°C, 500°C, 1000°C are based on the synthetic samples. The transition plane corresponds to  $T_{\text{equil}} = 1000 - 1100^\circ\text{C}$ . Increasing Al,Si order within topochemically monoclinic samples due to a decrease of  $T_{\text{equil}}$  lowers the plane (Kroll *et al.*, 1980, Eq. 3). Sources of data: Laves (1952), MacKenzie (1952), Kroll *et al.* (1980, Eq. 1 for  $T_{\text{equil}} = 1000^\circ\text{C}$ ), this paper: Figure 3 and 6 where  $T_{\text{displ}} = 1140^\circ\text{C}$  is taken at the intersection of the curve of the displacive transformation with the (dry) solidus curve.

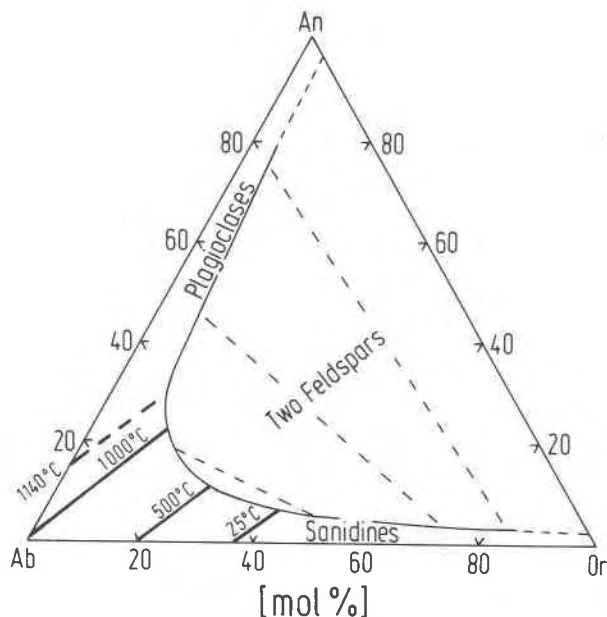

Fig. 8. Approximate representation of the phase relations of rapidly cooled, high-temperature ternary feldspars. The plane of the displacive transformation is taken from Figure 7, the solvus (900°C, 0.5 kbar) and three tie-lines from Seck (1971). The phases that occur above the transition plane are Or-containing (Na,Ca)-monalbites and An-containing monalbite-sanidine mixed crystals; (Na,Ca,K)-analbites occur below the plane.

ibration temperature of a (Na,K)-monalbite by 100°C causes  $T_{\text{displ}}$  to decrease by 25°C to 30°C. The ternary feldspars were prepared from K-exchanged plagioclases heated at 1100°C, whereas natural feldspars grew at much lower temperatures. Thus, as expected, all natural specimens invert at lower temperatures than do synthetic ones. The plane of the displacive transformation in Figures 7 and 8 indicates approximately the highest temperatures at which the transition occurs on quenching. The lowest temperatures could only be found if we knew  $T_{\text{diff}}$  in the ternary field.

#### Acknowledgment

We would like to thank Ms. G. v. Cölln and Mrs. I. Schmie-mann for their careful assistance in collecting the data and drawing the figures.

#### References

- Corlett, M. and Eberhard, E. (1967) Das Material für chemische und physikalische Untersuchungen an Plagioklasen. (Teil I der Laboratoriumsuntersuchungen an Plagioklasen). Schweizerische Mineralogische und Petrographische Mitteilungen, 47, 303-316.
- Czank, M. (1973) Strukturuntersuchungen von Anorthit im Temperaturbereich von 20°C bis 1430°C. Ph. D. Thesis, ETH, Zürich.
- Eberhard, E. (1967) Zur Synthese der Plagioklasse. Schweizerische Mineralogische und Petrographische Mitteilungen, 47, 385-398.
- Kroll, H. (1971) Feldspäte im System  $\text{KAlSi}_3\text{O}_8$ - $\text{CaAl}_2\text{Si}_2\text{O}_8$ - $\text{NaAlSi}_3\text{O}_8$ : Al,Si-Verteilung und Gitterparameter, Phasen-Transformationen und Chemismus. Inaugural-Dissertation der Westf. Wilhelms-Universität, Münster.
- Kroll, H. (1978) The structure of heat-treated plagioclases An<sub>28</sub>, An<sub>52</sub>, An<sub>69</sub> and the estimation of Al,Si order from lattice parameters (abstr.). Physics and Chemistry of Minerals, 3, 76-77.
- Kroll, H. and Bambauer, H. U. (1971) The displacive transformation of (K,Na,Ca)-feldspars. Neues Jahrbuch für Mineralogie, Monatshefte, 1971, 413-416.
- Kroll, H. and Müller, W.F. (1980) X-ray and electron-optical investigation of synthetic high-temperature plagioclases. Physics and Chemistry of Minerals, 5, 255-277.
- Kroll, H., Bambauer, H.U. and Schirmer, U. (1980) The high albite-monalbite and analbite-monalbite transitions. The American Mineralogist, 65, 1192-1211.
- Laves, F. (1952) Phase relations of the alkali feldspars. I. Introductory remarks. II. The stable and pseudo-stable phase relations in the alkali feldspar system. The Journal of Geology, 60, 436-450 and 549-574.
- Laves, F. (1960) Al/Si-Verteilungen, Phasen-Transformationen und Namen der Alkalifeldspäte. Zeitschrift für Kristallographie, 113, 265-296.
- MacKenzie, W.S. (1952) The effect of temperature on the symmetry of high temperature soda-rich feldspars. American Journal of Science, Bowen volume, 250A, 319-342.
- Schirmer, U. (1976) Die Ordnungen der diffusiven und der displaziven Umwandlungen bei Na-reichen Alkalifeldspäten. Diplomarbeit, Münster.
- Seck, H.A. (1971) Koexistierende Alkalifeldspäte und Plagioklasse im System  $\text{NaAlSi}_3\text{O}_8$ - $\text{KAlSi}_3\text{O}_8$ - $\text{Ca}_2\text{Al}_2\text{Si}_2\text{O}_8$ - $\text{H}_2\text{O}$  bei Temperaturen von 650°C bis 900°C. Neues Jahrbuch für Mineralogie, Abhandlungen, 115, 315-345.
- Smith, J.V. (1974) Feldspar Minerals. I. Crystal structure and physical properties. Springer-Verlag: Heidelberg.
- Viswanathan, K. (1971) A new X-ray method to determine the anorthite content and structural state of plagioclases. Contributions to Mineralogy and Petrology, 30, 332-335.

Manuscript received, May 20, 1980;  
accepted for publication, January 6, 1981.