

A NEW TYPE OF MONOCHROMATIC LIGHT SOURCE¹ALBERT B. PECK, *University of Michigan*

All scientific workers who have had occasion to make use of monochromatic light sources have doubtless had the experience that one type of source gives suitable results in some cases and not in others. The writer believes, however, that the device here described possesses sufficient merit in point of compactness, ease of manipulation, and in the results obtained, to warrant attention being called to it as an aid to others engaged in the type of work for which it is adapted and as a possible aid in other lines.

This monochromatic light source is simply an adaptation of the Monroe platinum filtering crucible, one in which the filtering agent is platinum sponge. Platinum sponge will absorb considerable quantities of salt and it will be found that the flame from this source is sufficiently intense for practically all ordinary laboratory work where monochromatic light is desired, such as for refractive index determinations by prism methods, the Abbe refractometer, and immersion methods with the microscope. It, furthermore, gives a pure flame of any desired salt containing very little contamination of sodium; if this does occur it may be eliminated by boiling in acid, washing in distilled water and re-impregnating. It also has the advantage of neatness and compactness, necessitating but one flame to furnish both the heat and the color. In a "life test" one of the cylinders containing a lithium salt, which is rather volatile, was burned at intervals which totalled approximately 24 hours and at the end of the period was apparently as intense as at the start. It is obvious, therefore, that only occasional renewal of the salt is necessary.

The starting point in making the monochromator is a thin piece of sheet platinum one half to three fourths of an inch square. This is riddled with small holes by a needle point, as closely placed as possible and yet have the sheet retain a reasonable amount of strength.

The next step is to precipitate $(\text{NH}_4)_2\text{PtCl}_6$ from a solution of H_2PtCl_6 by the addition of NH_4OH and NH_4Cl . This precipitate is filtered onto a filter paper and the resulting paste is worked into the pin-holes in the platinum sheet by rubbing the paste around

¹ Paper presented at the annual meeting of the Mineralogical Society of America, Amherst, Mass., December 29, 1921.

on the sheet with the rounded end of a glass rod or other suitable means. Too much paste should not be put on at first in order that there may not be a large loss of material.

The platinum sheet, impregnated with paste, should then be slowly dried over an open flame, care being taken that the drying does not take place fast enough to cause sudden steam expansion and consequent forcing of the paste out of the holes. When the drying has been sufficient to expel the liquid occluded in the paste, the sheet may be inserted into a hot flame and given a thorough ignition. The result of this is to drive off the volatile NH_3 and Cl constituents of the paste, leaving behind in the holes a brown or black mass of platinum sponge. More paste is then worked into the holes and again heated and ignited. Usually two or three such treatments are necessary to completely fill the holes with sponge. If a microscope is handy, the process can be followed and it can readily be seen when the holes are completely filled.

The next step is to attach a stiff wire to the sheet. For this purpose a piece of platinum or copper wire approximately one sixteenth inch in diameter is satisfactory. It may be attached either by welding the two or by running the wire through a hole near the edge of the sheet and making it tight by twisting.

After the wire is attached the sheet is rolled into a cylinder or helix of about one eighth to one quarter inch outside diameter. This should be done carefully to avoid dislodging any of the platinum sponge from the pin-holes.

The sponge is then ready to be impregnated with some salt to give the desired flame color. The cylinder should be immersed in a moderately concentrated solution of NaNO_3 or NaCl , for example, and then slowly dried over an open flame observing the same precautions as in drying the $(\text{NH}_4)_2\text{PtCl}_6$ paste. When dry it may be strongly ignited and as it becomes hotter, the flame color becomes more intense. This should be repeated two or three times in order that the platinum sponge may have a chance to absorb as much salt as possible. For red flames, LiNO_3 or LiCl should be used.

For holding the cylinder in the flame a simple device as shown in the illustration (Fig. 1) was constructed. It consists essentially of a brass collar which may be slipped over a Bunsen or Meeker burner and is held in place by a small set-screw. On the opposite side a small hole was bored vertically through the collar, large enough to take the wire attached to the cylinder. The wire also

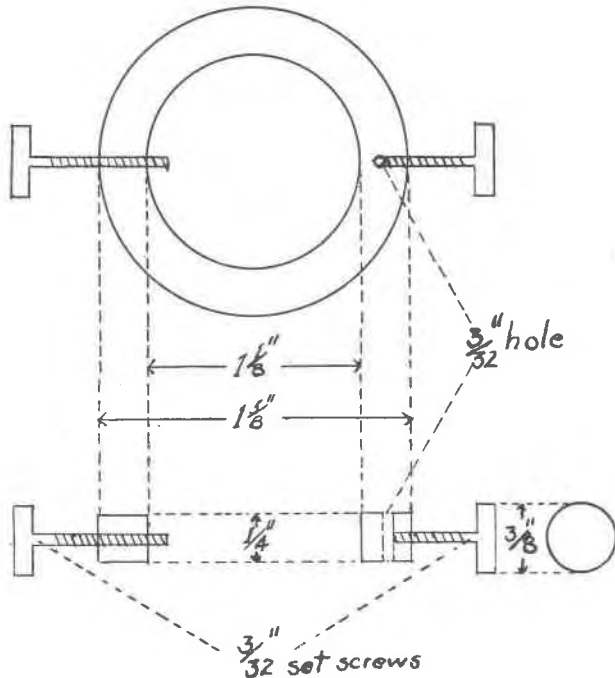

FIG. 1. Collar mount for Meeker burner

may be held at any point by another set-screw and thus the cylinder, bent at any desired angle into the flame, may be raised and lowered. For a Bunsen burner a collar of about five eighths inch internal diameter is generally large enough. For the ordinary Meeker burner one of one and one eighth inches diameter is sufficient. The latter burner is more satisfactory since it gives a hotter, broader and steadier flame, less influenced by air currents.

The writer wishes to record here that the idea of adapting the principle of the Monroe crucible to a monochromatic light source is not his exclusively but rather that of Dr. Edward Schramm, research chemist for the Onondaga Pottery Company, at whose suggestion and by whom it was developed during the summer of 1921. The collar for attaching it to the burner is of later development.