

Sample manipulator and quenching apparatus for high-temperature, 1-atm experiments¹

MICHAEL T. NANEY

Chemistry Division, Oak Ridge National Laboratory, Oak Ridge, Tennessee 37831

FRANK H. WARD

Plant and Equipment Division; Oak Ridge National Laboratory, Oak Ridge, Tennessee 37831

ABSTRACT

A self-aligning, guide-track apparatus has been adapted to a vertical-tube gas-mixing furnace for use in sample loading and quenching of high-temperature, 1-atm experiments. This apparatus facilitates experimentation with materials that cannot—or should not—be attached to a platinum wire-loop.

INTRODUCTION

The platinum-loop experimental technique (Donaldson et al., 1975) is widely used in 1-atm investigations of silicate-melt equilibria and crystallization. This method maximizes interaction between the sample and the furnace atmosphere, while minimizing loss of iron from the sample to the wire "crucible." However, several problems are encountered during operations that require moving samples in and out of the small bore of the vertical-tube furnace. These include (1) accidental contact of samples with the hot furnace wall during insertion, positioning, or withdrawal maneuvers; (2) accidental contact of samples with the zirconia oxygen-sensor which is normally in the hot zone of the furnace (such contact can result in sample loss and, more unfortunately, contamination and subsequent malfunction of the sensor); and (3) poor adhesion of some types of samples to the platinum wire-loops, making them prone to falling off the wire when lowered into the furnace.

GUIDE-TRACK ACCESSORY

A simple accessory helps to alleviate these difficulties by permitting rapid and precise sample insertion, manipulation, and withdrawal. This apparatus (Fig. 1) is designed to be used with water-cooled furnace end-caps built according to the design described by Williams and Mullins (1981). The main component of the equipment is a guide track (Fig. 2a) fabricated from 1.25-in. aluminum-metal angle stock. The angle stock is heli-arc welded to a base plate (Fig. 2b) that permits attachment to the furnace cap. The top of the guide track is attached to a rigid support (with an angle bracket) to eliminate stresses on the furnace cap and hot furnace tube when the guide track is in use. The usual alumina ceramic sample-support rod is fitted

with a short, cylindrical collar (Fig. 2c), which provides a mating surface for the guide track. This collar is fabricated from aluminum-metal bar stock that is machined to a diameter of 1.5 in. to provide a self-centering assembly. Both ends of the collar are fitted with standard O-ring vacuum fittings to ensure secure attachment of the collar to the alumina ceramic rod. A clamp (Fig. 2d) machined from aluminum-metal plate is fitted with a ma-

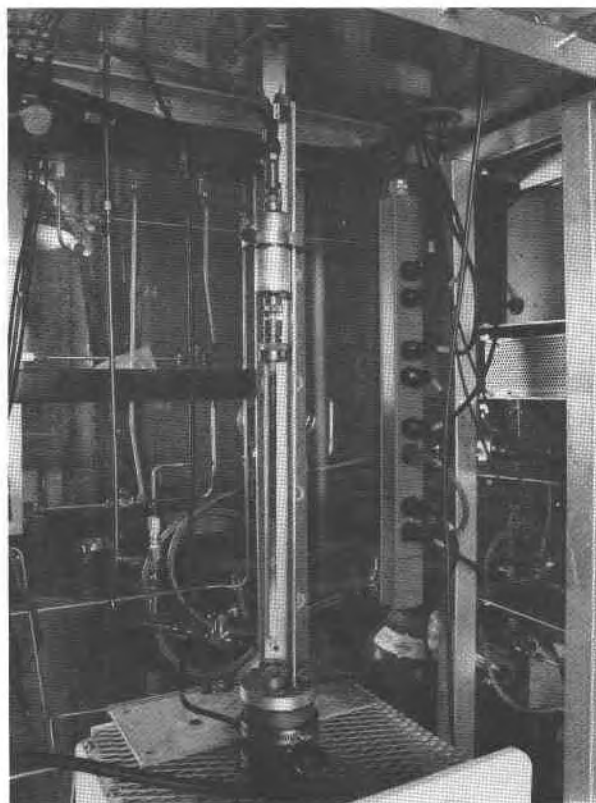

Fig. 1. Photograph of the sample manipulator and quenching apparatus.

¹ Research sponsored by the Division of Engineering and Geosciences, Office of Basic Energy Sciences, U.S. Department of Energy, under contract DE-AC05-84OR21400 with Martin Marietta Energy Systems, Inc.

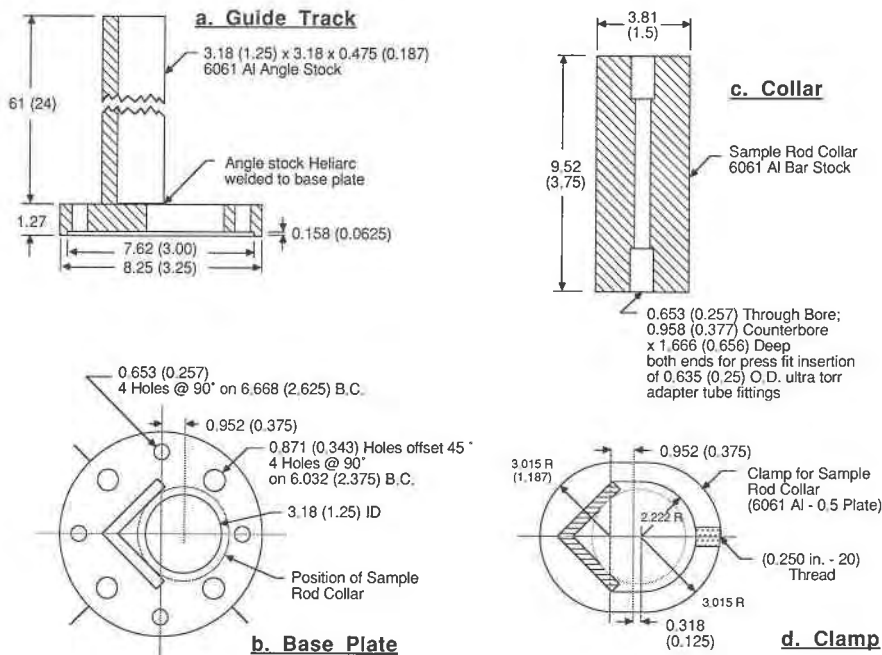

Fig. 2. Design details of the sample manipulator and quenching apparatus. Dimensions are in centimeters unless otherwise indicated. Dimensions in parentheses are the inch equivalents. (a) Section view of guide track and attached base plate. (b) Plan view of base plate showing attached guide track and position of sample rod collar. (c) Section view of sample rod collar. (d) Plan view of sample rod clamp.

chine screw. This clamp permits (1) locking of the sample-support assembly to the guide track after the sample is lowered into the furnace; (2) locking of the sample assembly in a position above the furnace prior to experimentation to facilitate attachment of samples; and (3) locking of the sample assembly in a position that facilitates termination of the experiment by gas-jet quenching.

Using the guide track described above, insertion, manipulation, and withdrawal of most experimental samples become routine operations. Therefore, the experimenter can concentrate on the timing of sample insertion and withdrawal, or on sample positioning with the aid of a mirror placed below the temporarily opened drop-quenching port in the bottom furnace cap. However, the apparatus is especially advantageous when experiments involve the use of starting materials that do not adhere well to a platinum wire. In this circumstance, samples can be successfully lowered into the furnace by simply laying them on top of the platinum wire-loop prior to insertion into the furnace. The guide track permits precise, controlled vertical movement of the sample support rod and attached platinum wire-loop so that nonadhering samples remain atop the platinum loop. This capability was found

to be particularly useful for a study in which short cylinders of obsidian were used as starting materials.

In summary, the advantages to be gained by using a guide-track assembly in high-temperature, 1-atm experimentation are (1) ease and speed of insertion, manipulation, and withdrawal of samples and (2) handling of "difficult" or special samples that are not secured to the platinum wire-loop prior to experimentation.

ACKNOWLEDGMENTS

The authors thank J. G. Blencoe and S. E. Swanson for reading an earlier version of this note, and G. Lofgren for a thoughtful review.

REFERENCES

- Donaldson, C.H., Williams, R.J., and Lofgren, G. (1975) A sample-holding technique for the study of crystal growth in silicate melts. *American Mineralogist*, 60, 324-326.
- Williams, R.J., and Mullins, O. (1981) JSC systems using solid ceramic oxygen electrolyte cells to measure oxygen fugacities in gas-mixing systems. U.S. National Aeronautics and Space Administration Technical Memo 58234.

MANUSCRIPT RECEIVED JUNE 7, 1985

MANUSCRIPT ACCEPTED JANUARY 17, 1986